



Automated warehouses





 **MECALUX**



Modern technologies used in logistics systems and processes enable users to dramatically improve the efficiency of storage, handling, preparation and dispatch of all types of goods.

Automated warehouses and material handling systems give companies the advantage over their competitors, with respect to cost savings, improved productivity, range of products and superior customer care, just to mention a few.

The automated applications are becoming more important than the traditional setups in warehouses and supply chain operations.





AUTOMATED STORAGE SOLUTIONS

Advantages

Productivity and availability

- Highly productive goods receipt and dispatch processes.
- Top performance, extend business hours, easy maintenance, etc.
- Continuous workflows.

Labour cost savings

- Reduced numbers of forklift operators, order pickers and administrative staff.
- Less material handling equipment needed.

Lower maintenance costs

- Reduce damage due to improper usage.
- Stop wear and tear from misuse and mishandling
- Paving, structures, etc., with fewer technical requirements.

Total safety of personnel

- Installations designed for low level of human intervention.
- Integrated safety systems.
- Ergonomic workstations.
- General protection of personnel.

Loads safe and sound

- Goods secured and enclosed.
- Eliminate losses from unknown sources.
- Goods kept in perfect condition.
- Eliminate breakage due to mishandling.
- Reduce the need for repetitive checks.

Real-time inventory

- The system is equipped with management software, enabling the identification and control of all goods.
- Precise product tracking.
- Movements logged and controlled.

Maximum use of space

- High-density storage of goods.
- Reduction in built surface area.
- Use of height maximised
- Reduction in built volume.
- Storage systems in blocks.
- Flexible,scalable solutions.



ANALYSING SOLUTIONS AND PROJECT DEVELOPMENT

Mecalux has developed its own method of designing automated solutions for customers, as shown in the following diagram:

Stages of project development

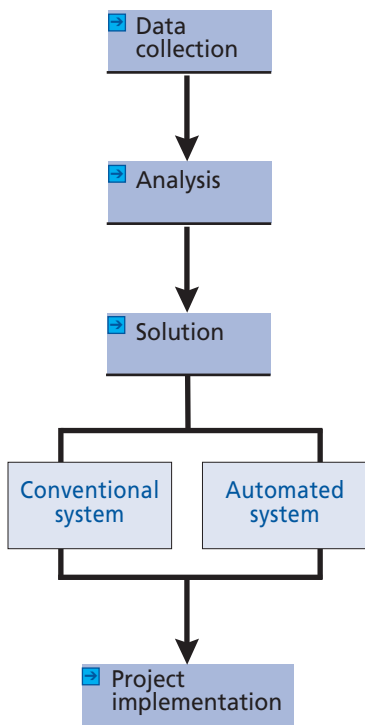

Stage 1

→ DATA COLLECTION

Need identification: Reasons for automating

Gathering the relevant data used to configure a logistics system is necessary to formulate a solution that meets the needs of the customer:

- Growth forecast.
- Increase in storage capacity.
- Number of errors.
- High number of losses through unknown causes.
- Level of stock breakage.
- Increasing demand from customers.
- Relocation of facilities.
- Types of products.

Among the information which must be collected is the data related to the load to handle (size, weight, perishables, traceability, hazardous components, legal and technical requirements, etc.), the static capacity of the warehouse (number and type of units to be stored) and the dynamic capacity of the system (entries, exits, single cycles, combined cycles, availability, frequencies, etc.).

The collection of data must be carried out correctly, taking into account the usefulness of the information to apply it appropriately in the project. The following points must be considered:

- Firstly, **reorganise and simplify** to get ready for automation. Chaotic processes should never be automated.
- Automation often entails **changes to operational methods**.
- Automation must be selective and focused on **repetitive tasks**.
- No matter how many processes are automated, people are still needed. Therefore, special care must be taken as to the participation, motivation and training of the personnel involved to achieve optimal results.



Stage 2

→ ANALYSIS

Feasibility study

Based on our experience in automated solutions for storage and material handling, Mecalux has developed a methodology which ensures a highly-detailed analysis of all a customer's data, capacities and needs.

- A, B, C product rotation.
- Data analysis.
- Determine flows and rotations.
- Examine deciding factors.
- Study procedures.
- Return on investment.

In the first stage, all potential technical solutions are studied which are able to meet the objectives of the installations. Each one of these designs is defined with variables and descriptors, such as the static capacity (storage volume), dynamic capacity (the installation's cycles and work pace), physical dimensions, number of personnel, number of automated machines (storage and transport), etc.

Once the logistics solutions have been modelled, they are then compared using an optimised framework to determine the best option.

The diagram below shows a comparison of two solutions (A and B) for heavy loads, demonstrating the different behaviours with respect to the operational costs depending on the cycles required in the installation.

Another issue that is considered in the logistics studies is the value of the investment and its profitability. So, two different solutions can be easily compared in terms of their profitability and the generation of value for the investor.

The variables studied include the IRR (Internal Rate of Return) and the return on investment, which indicate the time required to recover the investment for each of the proposed solutions.

HEAVY LOADS

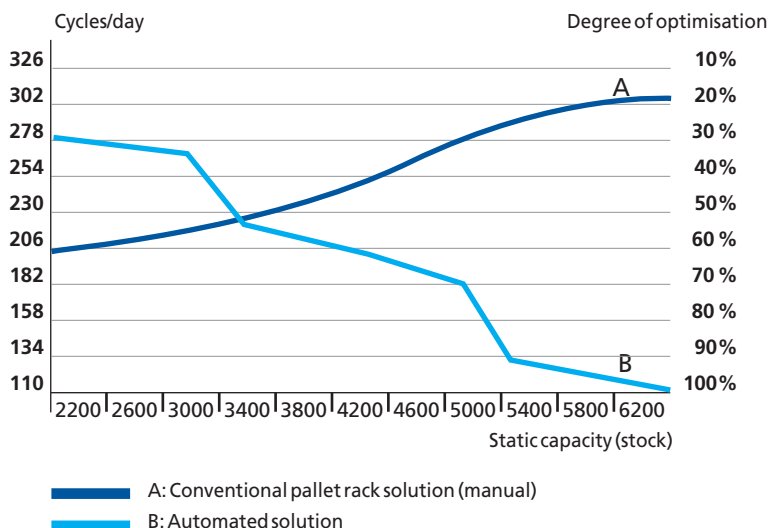



This study methodology is systematically applied to different variables, with the following benefits:

- The customer can rest assured that Mecalux will always offer the right solution.
- It is possible to make changes to the proposed design of the logistics solution design, thanks to the systematic study of the initial proposal.
- In the case of **future modifications and/or extensions** of the installations, the study is much more straightforward and **scalable**.
- The **proposed solutions always take into account the standard Mecalux products**. In this way, once an installation has been defined and contracted, the time to implement the engineering project is notably reduced.



Stage 3

→ SOLUTION

Developing a solution

The solutions Mecalux provides for its customers allow them, within a set investment, to manage their warehouses and handling equipment, while still enjoying all the benefits of automated systems.

An automated system requires a highly structured work philosophy, in which the warehouse is seen as an integrated distribution system.

Adapting to the different operational systems, needs and capacities of its customers, Mecalux faces the challenge of managing and automating warehouses through a range of solutions, from basic automation up to advanced automated features:

- Conventional pallet rack warehouse
- WMS + Conventional pallet rack warehouse
- WMS + Conventional warehouse + Autonomous automated system
- WMS + Automated warehouse
- WMS + Automated warehouse + Conventional pallet rack warehouse
- WMS + Automated warehouse + Picking stations
- WMS + Automated warehouse + Sequencing + Picking stations
- Complex automated systems

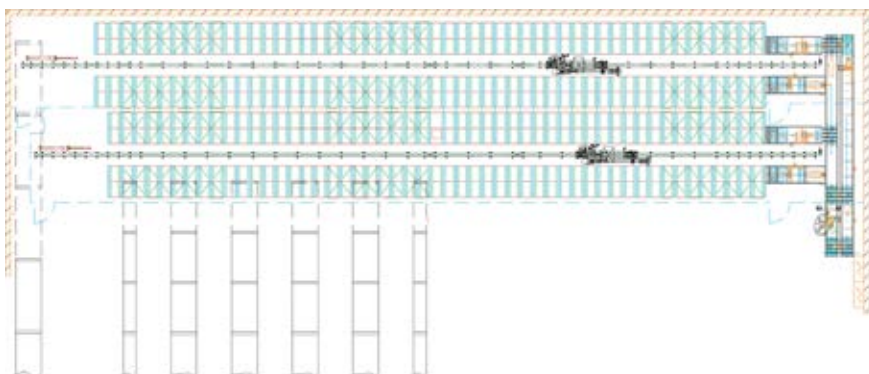

At all levels of automation, the main test Mecalux faces is to design installations which are adaptable and provide the functionality required by new and ever-changing logistics management.

The section entitled Computer Systems for Management and Control details each level and its characteristics.



Stage 4

→ THE PROJECT

Implementing the project

- Defining project specifications
- Assembly of the installation
- Commissioning
- Training

This stage is complex as countless technological factors are involved, interacting with each other during the project implementation and in the same workplace.

As a consequence, Mecalux implements its own work method for developing projects to complete the installation, to improve productivity on the site, to meet the development times and to limit unexpected problems.

Firstly, Mecalux carries out 100% of its project's engineering works using its own team of experts, specialised in mechanics, electrical systems, electronics and software.

Mecalux can then guarantee compliance with all the **technical and legal regulations applicable to all installations**, such as metal structures in construction, fire prevention standards, occupational health and safety regulations, safety plans, etc.

Each installation that Mecalux implements, irrespective of its complexity, has a dedicated site manager who provides support and supervision, and who is responsible for: tracking the project's progress from start to finish; coordinating the different teams which need to work on the installation; and guaranteeing that the work is always done as per the project's technical specifications, current regulations and legislation, and in compliance with the safety plan. Regular meetings are held with the customer throughout the installation process.

In most cases, work follows this sequence:

1. **Assembly of racks.**
2. **Mechanical assembly** of the automated equipment (storage and transport).
3. **Electrical assembly** of the automated equipment (storage and transport).
4. **Commissioning of the control system.**
5. **Commissioning of the management system.**
6. **Start-up of the installation, training and hand over of the installation.**

When the project has been completed, the installation is handed over to the customer, after all the equipment has been commissioned. At this point, all the technical, legal and operational documents are given to the customer.

A complete **training programme** for all the staff involved to any degree in the management of the installation is also conducted at this moment. The primary goal of this transfer of knowledge and documents between Mecalux and the customer is to achieve the maximum performance in the logistics operations with as little post-set intervention as possible.

In all cases, Mecalux proposes and consults on the creation of **preventive maintenance** plans for the installation through a team of highly-qualified technical specialists in mechanics, electrical systems, electronics and software. This minimises the risk of damage due to system misuse and increases the availability and service life of the equipment.

Mecalux has a team of professionals who are available to carry out these maintenance tasks and urgent repair work, 24 hours a day, 365 days a year. Both the customer's and the technical teams of Mecalux who work in the installations can always count on the **telephone assistance service** and **remote maintenance** centre.



TURNKEY PROJECTS

Mecalux offers turnkey projects for all installations getting automated solutions to provide a more comprehensive service. In these cases, Mecalux's involvement in the project more covers areas that are not strictly linked to material handling equipment. These include:

- Core project
- Project management
- Construction work
- Cladding
- Temperature controlled cold-storage
- Fire safety systems

Core project

An industrial project must be based around a core project, which defines the overall design of the solution. Its focus is a detailed technical description that is useful in managing the contracting of the project's different sections, along with all the legal work necessary.

The core project must deal with, among others, the location of the industrial facility, the size of the plot, the built surface area and volume, power consumption, the basic defining of the buildings' structures, the required calculations, and the environmental and safety plans.

Project management

The primary role of the project management team is to ensure the project progresses according to the technical specifications of the core project. As a consequence, the tendering process, technical supervision and contracting is carried out for all of the different areas that comprise the project.

In addition, an exhaustive supervision is performed on the work done in the installation, in accordance with the technical specifications and the laws in force.



The project management team coordinates the work tasks, ensuring the different elements run smoothly, that the progress of the installation is optimal and the goals of the projects are fulfilled.

The team is also responsible for different legal and administrative issues applicable to the project in accordance with the regulations in force.



Construction work

Construction work forms an important part of any turnkey project. The implementation of automated logistics generally consists of the following:

- Slab
- Structure
- Additional building work

Slab

The slab is one of the most important construction elements of an industrial installation. A building's slab provides a stable base which is able to withstand the forces produced by all of the components of the warehouse and its contents.

Therefore, before starting to building, it is necessary to know all forces that will be transmitted to the slab by the installation and what it will be used for (racking, conveyors, special machinery, circulation of material handling equipment, etc.). It is also absolutely essential to carry out an in-depth study of the land on which the slab is to be laid, to determine its strength.

The foundations of the slab are designed according to the results of a geotechnical study. There are numerous possible concrete foundations. For instance, a compacted layer of the subsoil may be sufficient. However, when working on poor resistance land, solutions involving pile or micropile foundations are a must.

The slab must be calculated according to the forces transmitted. Based on this, other aspects are then defined, such as: concrete type, mesh or resistant fibre, thickness, levelling, surface finishes, drainage system, location of joints, the slab laying method, etc.

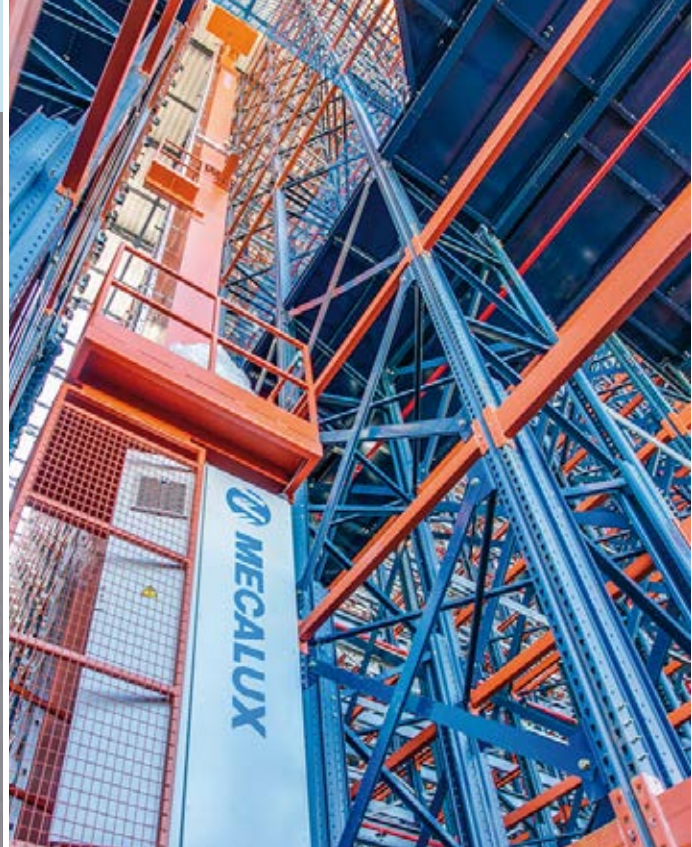

Structure

In the case of clad-rack warehouses, the basic structure is formed by the racking itself which, in turn, functions as the warehouse.

The structures of clad-rack buildings must be calculated applying the law of material resistance, using powerful and sophisticated programmes and calculation algorithms. The load being stored must always be taken into account (dimensions, weight, distribution), along with the dead weight of the structure and external actions, such as wind (pressure or suction), snow, earthquakes and other live loads.

All these calculation factors are included in the different regulations and laws, which are usually featured in the Technical Building Codes of each country. The widespread geographical presence of Mecalux has provided the company with knowledge of the technical factors affecting structures in any location. In the case of industrial buildings with

conventional pallet rack structures, rather than clad-rack buildings, the current regulations should also be applied. The most frequently used materials are concrete and steel, with hot-rolled profiles.

When calculating conventional pallet rack structures, issues such as dead weights and external loads (wind, snow, earthquakes, etc.) should be considered, as well as the height of the building, the distance between pillars and the length of the building's open spaces.

Additional building work

This section deals with any building work completed inside the building, along with any masonry work.

The technical definition of this part is affected by the floor plan of the industrial installation, and the connection between the different spaces and their functions.

This technical definition and its subsequent implementation is also part of the work completed by Mecalux during the installation.



Cladding

Cladding is a complex element of industrial buildings. It can endow a building with the required impermeability, insulation and sanitary finishes on an industry-by-industry basis, along with a level of fire resistance determined by regulations in force as per the contents of the installation, the materials it is made from and its location (UNE 23 727-90, CSTB, EN-13501-01, etc.).

The cladding can either be fitted to the wall sections, or serve as a roof for all sections where the cladding is suspended.

One type of cladding is chosen over another depending on where the cladding is fitted (indoor or outdoor), the technical features and solutions used in the installation and according to the weather conditions it must withstand.

Mecalux normally uses steel or aluminium to clad its installations. Another very common solution is the use of pre-manufactured tiles, since they are easy to make and install in warehouses that require a guaranteed perfect installation and optimal finish.

One case in particular stands out: refrigerated panels to insulate cold or freezer stores that run at below zero temperatures. In these installations, the temperature difference between the inside and outside of the building can be as much as 70°C. So, the installation must be completely airtight. This avoids excessive power consumption, along with problems of humidity and frost, which would result in machine malfunctions in these environments.

The panels which Mecalux uses in cold store installations are manufactured using a "sandwich-type" solution, in which the two external surfaces of the panel are formed by lacquered steel sheets with an interior thermal insulation material of 100 mm or 200 mm, according to the temperature difference they need to withstand. The insulation material used can either be polyurethane (PUR) or PIR, if a greater fire resistance is needed. Whichever is chosen, Mecalux's solution is based on a pre-manufactured modular system, enabling a quick set up and that the installation is perfectly sealed.



Temperature controlled cold-storage

Cold stores which need special temperatures maintained, i.e. a temperature that is not ambient temperature, require the installation of specific refrigeration equipment.

Aspects which significantly affect the design of cold-storage installations include the temperature of conservation, the type of goods, the layout of the load in the building, the entry or exit flows and the automated installations operating inside the cold store.

In a cold-storage warehouse it is absolutely essential to correctly define the equipment and types of refrigeration required, along with the vent network which distributes the cold through the whole building.

Mecalux is a leader in the design and implementation of controlled and subzero temperatures solutions, both in conventional pallet rack structures and clad-rack buildings. In these cases, automated solutions are very commonly employed, since they enable a significant reduction in the volume to be cooled, which means considerable savings in energy costs. Furthermore, they also reduce the need for operators to work in subzero temperature environments.



Fire safety systems

The risk of fire in an industrial warehouse installation is, as a rule, high and depends on factors such as the proportion of combustible material of the goods stored, the packaging used (cardboard, wood, etc.), the type of material handling equipment chosen, the storage means, etc.

The combustibility of the goods stored, i.e., their flammability and speed of combustion, along with their distribution in the building have a decisive influence on the outbreak of fire and its spread. A stringent, complex set of regulations exists to minimise the risk of fire and its damaging effect, which must be applied. This makes it necessary to install fire safety systems in installations in most cases.

A fire safety system is made up of a variety of different measures.

- **Construction measures of the building itself.** It is always recommendable to use special building materials, preferably class F60, to reduce the risk of fire. It is also common practice to divide the area into separate sections, which do not hinder the use of the installations but which do prevent fire from spreading rapidly.
- **Organisational measures to minimise the risk of fire.** These include the prohibition of smoking in areas of high flammability, the confinement of the most flammable goods in closed-off places, and the drawing-up of emergency and evacuation plans, etc.
- **Technical measures for detecting and extinguishing fires.** Mecalux offers its best technical solutions in this area, such as the oxygen reduction system.

Fire detection

With respect to installations for the detection of fires, automated point-to-point systems can be used. In most cases, the fire will produce smoke and waste from combustion. This happens before there is a significant increase in temperature or flames appear.

It is therefore advisable to use a smoke detection system and not one that detects heat changes in the environment, as the response time in these situations is the key to reducing damages.

The speed of automated fire detection depends to a great extent on the distribution of the detectors and the distance between them. Evidently, the smaller the distance between the detectors, the quicker the fire is detected.

In high-bay warehouses it is also essential to assess the delay represented by only fitting detectors on the ceiling. The time it takes for smoke to reach the top of the building could be critical. Because of this, detector must also be fitted on different levels in high-bay warehouses.



Extinguishing fires

In the field of fire extinguishing equipment there is also a lot of applicable regulations (RT2-CHE, RT1-ROC, etc.), which have a decisive influence on the selection and subsequent distribution of the basic components of the installation.

Basic components of the installation include automatic water sprinklers. These are devices which spray water automatically at the point of fire in sufficient quantities to control it or to prevent it from spreading.

The water is pumped to the sprinklers through a system of pipes, which is generally suspended from the roof or from the racks. The sprinklers are fitted to the pipes and cover a surface area of 9 to 20 m², according to the type of load and its location. The sprinkler holes are normally blocked by a disc, which remains in the closed position until it is opened by a heat sensitive element (a glass bulb or eutectic fusible alloy). In this way, only the sprinklers covering the area which has reached a predetermined temperature are activated, which causes the heat sensitive element to react.

Another basic construction component of fire extinction installations is the water network. Each network has a tank connected from the main fire prevention pipe, which supplies water through a shut-off valve to a control and alarm valve.

The networks can be based on a wet pipe system or a dry pipe system. The first case means the pipes situated before and after the alarm valve are permanently filled with water. This type of system must not be used in premises with temperatures below 4 °C to prevent the water from freezing. In such situations, a dry pipe system is employed, which contains water above the alarm valve and uses pressurised air. The pipe fills with water and the sprinklers activate only when the valve is triggered.

An alternative to fire sprinkler systems and a water network is the use of the hypoxic air technology to reduce the level of oxygen in the atmosphere. This method is based on making the warehouse less combustible by lowering the oxygen concentration below the point necessary for combustion.

All of these aspects are highly technical, and require adequate study of the distribution and placement of the detection systems for each case, along with the use of the best extinguishing system. Mecalux's technical departments carry out this task in all turnkey projects.



Stacker Cranes for Pallets

Stacker cranes are machines designed for the automated storage of pallets. They travel along the aisles of a warehouse, carrying out the storage, placement and retrieval of goods.





CONTENTS

Stacker cranes for pallets	20	Aisle equipment	32
Automatic trilateral stacker cranes		Bottom guide rail	
Single-mast MTs		Top guide rail	
Twin-mast MTB0s		Positioning systems:	
Twin-mast MTBs		■ Beam detection	
		■ Pallet push/pull control	
Mechanical components	26	■ Laser rangefinders	
Masts		■ Absolute encoders	
Lower guide base or frame		Aisle change systems:	
Upper guide base		■ Curved tracks	
Hoisting operations		■ Transfer bridges	
Mobile hoisting frame or cradle		Operational modes	36
Extraction systems:		Automated mode	
■ Single-deep		Semi-automated mode	
■ Double-deep		Manual mode	
■ Triple-deep		Safety devices	37
■ Pallet Shuttle		Onboard safety equipment	
■ Roller conveyors		Aisle safety equipment	
Onboard conveyors		Wireless transmission systems	
Trilateral forks		Velocity control	
Electrical components	31		
Electrical cabinets			
Data transmission			



Mecalux stacker cranes have proven their efficiency in diverse sectors such as food and beverages, automotive, pharmaceuticals, spare parts, metallurgy, chemicals and public administration.

STACKER CRANES FOR PALLETS



Stacker cranes are machines designed for the automated storage of materials through automated mechanical movements. Storage and retrieval are carried out in the same movement (known as a combined cycle). This increases an installation's productivity, as well as reduces the resources required to run the machine.

The stacker cranes can carry out three movements to move the loads in the warehouse:

- **Down-aisle:** moving along the aisle on a rail
- **Vertically:** up and down the mast of the stacker crane.
- **Cross-aisle:** across the depth of the racks using the extraction systems fitted to the machine's cradle, which collect or position a pallet.

The principal types of stacker cranes are:

- **Single-mast** (recommended for loads of up to 1,500 kg).
- **Twin-mast** (recommended for moving two loads of up to 1,000 kg each, or one large load).

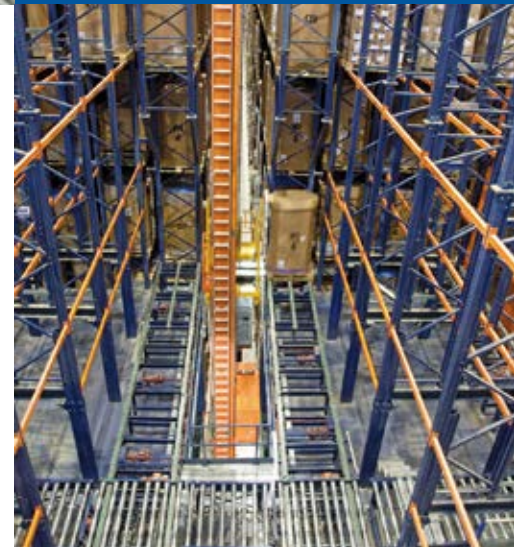

Mecalux stacker cranes are state-of-the-art machines with propulsion operated by vector-controlled frequency inverters, which are position controlled through laser rangefinders and are intelligently managed by either a PC or PLC.

The range of stacker cranes adapts easily to the needs of each warehouse in terms of load capacity, dimensions, building height and cycle times, covering a broad array of uses.

All of these systems can be adapted to special work conditions, such as freezing temperatures (-30 °C), extreme humidity or special features, including higher standard work speeds.

Furthermore, it has electronic energy-recovery devices, which account for considerable savings in monthly power consumption.

Automatic trilateral stacker cranes

Designed to handle operator-free automated systems in conventional pallet rack warehouses, this stacker crane does not need an upper guide rail. Its main advantages are:

- **Three-sided load retrieval**, of under 100 mm on the lower levels laterally and 0 mm when retrieving loads frontally.
- **Does not require an upper guide rail**, meaning it can be used in existing warehouses without reinforcing the racks.
- **Eight-wheel gears** make aisle changes of the transfer bridge easy, without a pit.
- **Fully automated operations** that connect to Easy WMS.



FEATURES

Max. height - single-deep	15,000 mm
Upper guide rail	No
Max. weight over entire height	1,200 kg
Max. load dimensions	1,300 x 1,100 x 2,300 mm
Type of extractor	Trilateral electric forks
Max. travel speed (V_x)	100 m/min
Max. travel acceleration (a_x)	0.3 m/s ²
Max. lifting speed (V_y)	38 m/min
Max. lifting acceleration (a_y)	0.3 m/s ²
Aisle change system	Transfer bridge without pit
800 mm and 1,000 mm Euro pallets	Yes
GMA or closed CHEP pallets	Yes

Single-mast MT stacker cranes for pallets

The new MT line is lighter, faster, and more energy efficient.

Designed to achieve the highest possible functionality and efficiency, select the most suitable stacker crane from the wide range of models, in terms of available space and goods to be handled.

There is a machine to suit each warehouse height, facilitating top cost savings for the installation.

Cover any storage need with stacker cranes ranging from the MT-1 model, ideal for shorter installations, up to the MT-5, which can reach storage heights of 45 m.

The table below details the technical features of Mecalux's line of single-mast stacker cranes.

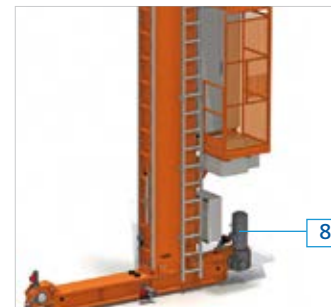
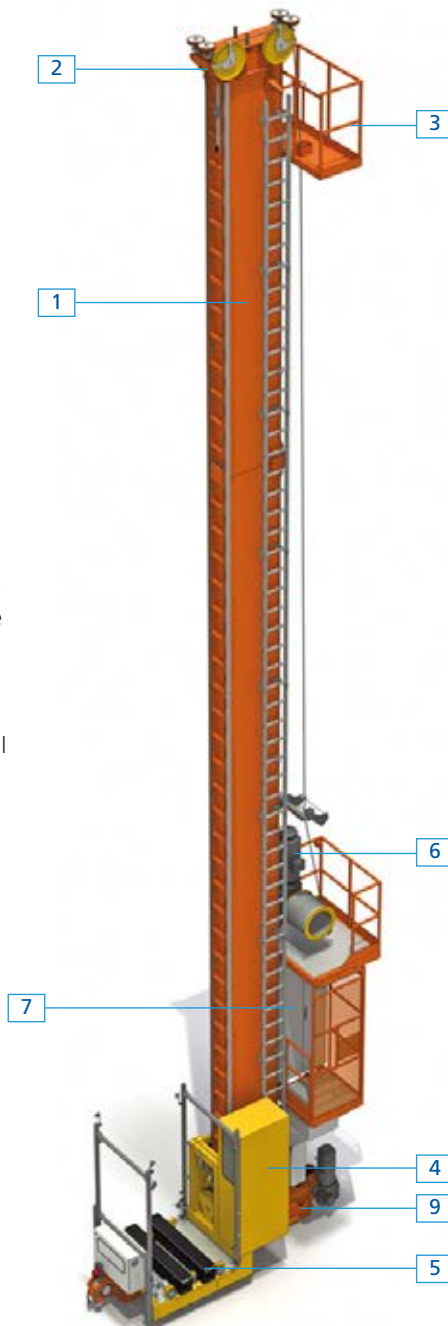

Core components

1. Mast
2. Upper guide base
3. Maintenance platform
4. Onboard cabin
5. Lifting cradle
6. Lift motor
7. Electrical cabinet
8. Travel motor
9. Lower guide base

FEATURES	MT-1	MT-2	MT-3	MT-4	MT-5
Max. height - single-deep	18,000 mm	24,000 mm	33,000 mm	36,000 mm	45,000 mm
Max. height - double-deep	15,500 mm	22,000 mm	27,000 mm	33,000 mm	45,000 mm
Single-deep telescopic fork	Yes				
Double/triple-deep telescopic fork	Optional				
Automatic Pallet Shuttle	Optional				
Max. load admitted	1,500 kg (SD) 1,000 kg (DD)	1,500 kg (SD) 1,000 kg (DD)	1,500 kg (SD) 1,000 kg (DD)	1,000 kg	1,000 kg
Max. travel speed (V_x)	220 m/min				
Max. travel acceleration (a_x)	0.5 m/s ²				
Max. lift speed (V_y)	66 m/min				
Max. lift acceleration (a_y)	0.6 m/s ²				
Side-mounted cabin	Optional				
Operations temperature range	From -30 °C to +40 °C				
Max. load dimensions	1,100 x 1,300 x 2,400 mm				
Pallet type	800 mm and 1,000 mm Euro pallets (EN13382)				
Energy recovery system	Optional				

Twin-mast stacker cranes (MTBO)

Fewer features but just as safe, these cranes were designed for high-capacity storage without using up much space. Twin-mast stacker cranes are affordable and energy efficient. Their main advantages are:

- **Deposit and pick up loads** at a very low levels, with a connection to automated conveyors.
- **Low energy consumption.**
- **Fully automated operations,** connected to Easy WMS.



FEATURES

Maximum height	18,000 mm
Upper guide rail	Yes
Max. weight over entire height	1,500 kg
Max. load dimensions	1,300 x 1,100 x 2,400 mm
Single-deep telescopic fork	Yes
Double/triple-deep telescopic fork	Optional
Automatic Pallet Shuttle	Optional
Type of extractor	Double-deep telescopic fork
Max. travel speed (V_x)	120 m/min
Max. travel acceleration (a_x)	0.3 m/s ²
Max. lifting speed (V_y)	38 m/min
Max. lifting acceleration (a_y)	0.3 m/s ²
800 mm and 1,000 mm Euro pallets/ GMA pallets	Yes

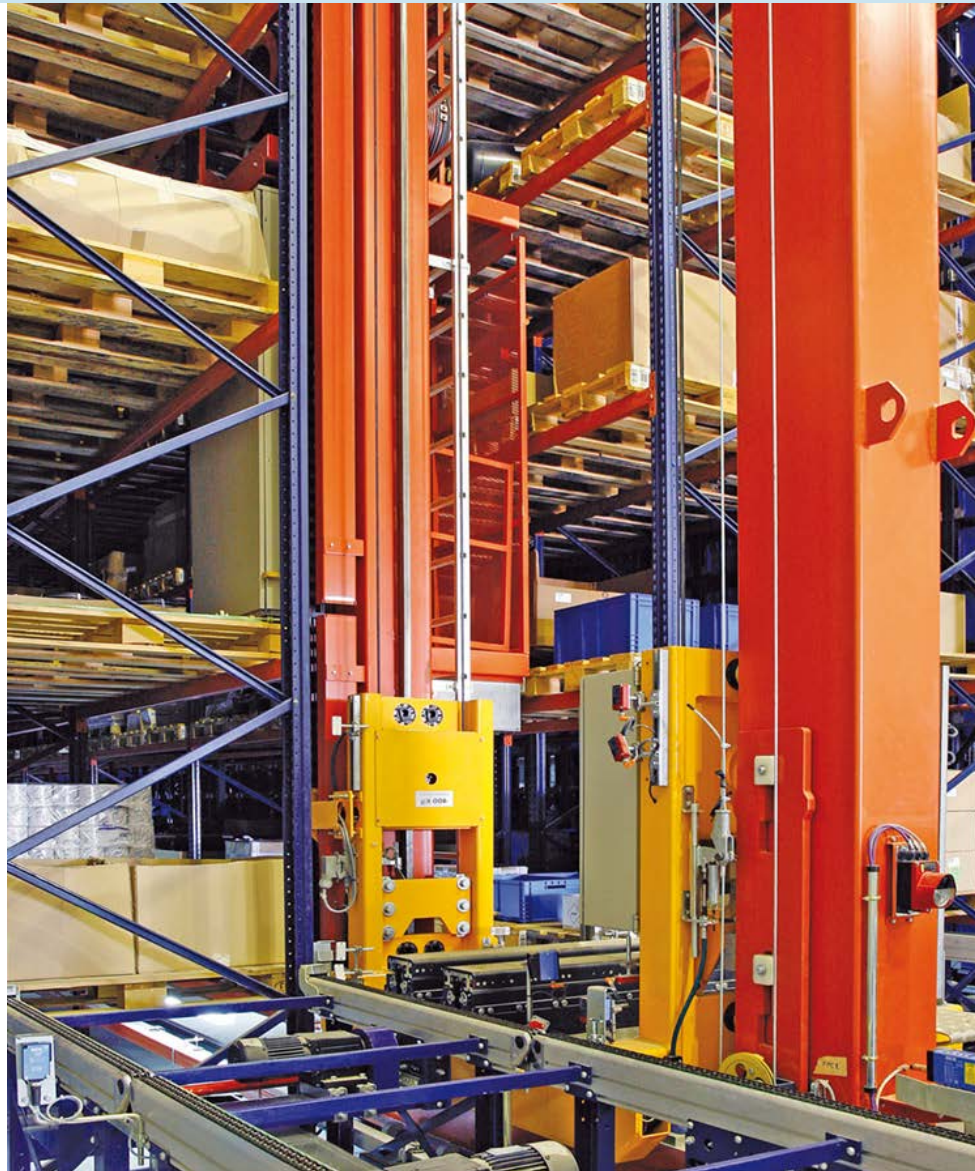

Twin-mast MTB stacker cranes for pallets

Twin-mast stacker cranes have been developed for more demanding storage situations. They offer enhanced performance in terms of load capacity and working speeds.

The lifting cradle operates between two masts, giving access to all levels, thus ensuring the installation is strong and sturdy.

This class of stacker crane also offers a wide range of machines, enabling optimal adaptation to the load's height and weight constraints. Mecalux's range of twin-mast stacker cranes are shown in the following table.

FEATURES	MTB-1	MTB-2	MTB-3	MTB-4	MTB-5	MTB-6	MTB-7
Max. height - single-deep	12,000 mm	17,000 mm	22,000 mm	27,000 mm	35,000 mm	40,000 mm	45,000 mm
Max. height - double-deep	–	12,000 mm	20,000 mm	27,000 mm	35,000 mm	40,000 mm	45,000 mm
Single-deep telescopic fork	Yes						
Double/triple-deep telescopic fork	Optional						
Retrieval systems using shuttle/roller conveyors	Optional						
Max. load admitted	1,500 kg						
Max. travel speed (V_x)	220 m/min						
Max. travel acceleration (a_x)	0.5 m/s ²						
Max. lift speed (V_y)	66 m/min						
Max. lift acceleration (a_y)	0.8 m/s ²						
Automatic Pallet Shuttle	Optional						
Optional raisable maintenance cabin or onboard static cabin	Yes						
Operations temperature range	From –30 °C to +40 °C						
Max. load dimensions	1,300 x 1,100 x 2,400 mm						
Pallet type	800 mm and 1,000 mm Euro pallets (EN13382)						
Optional energy recovery system	Yes						

Core components

1. Masts
2. Upper guide base
3. Maintenance platform
4. Onboard cabin
5. Lifting cradle
6. Lift motor
7. Electrical cabinet
8. Travel motor
9. Lower guide base

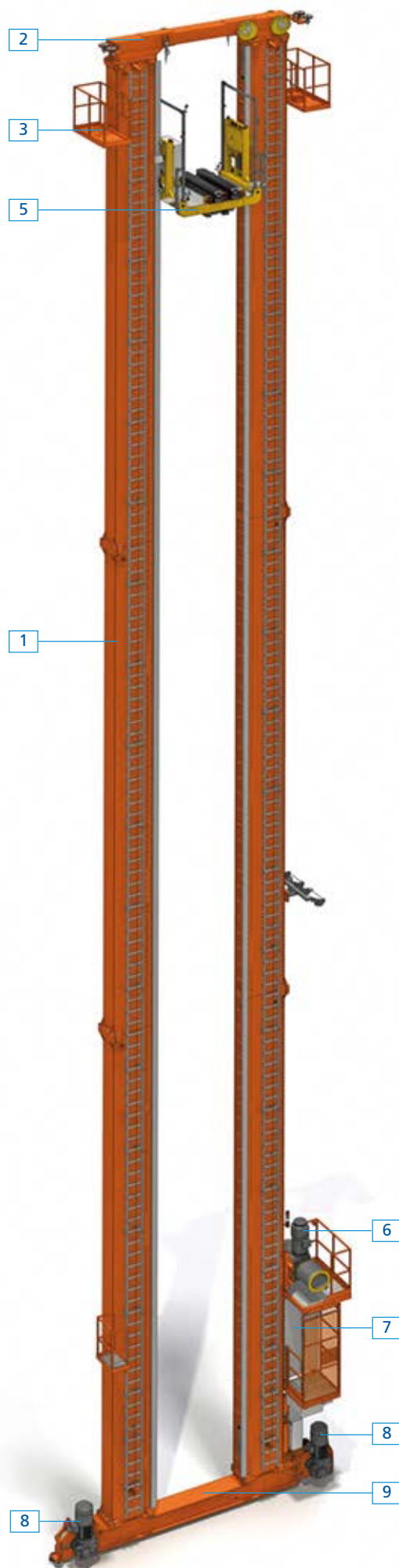
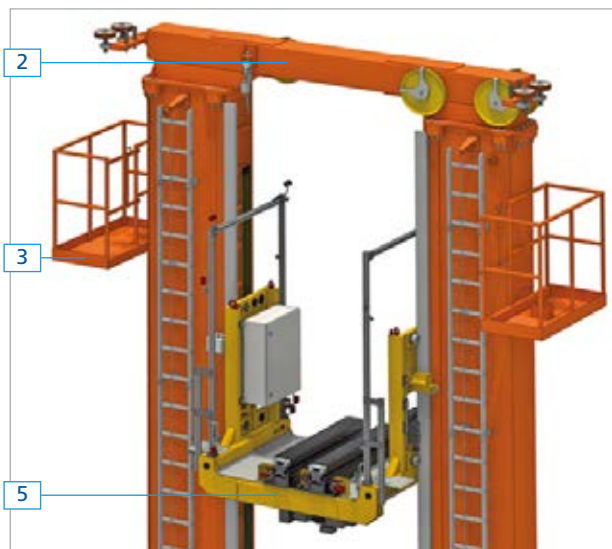



The design of the stacker cranes minimises the forces transmitted to the structure which supports them. In the long run, this prevents damage to the rack and warehouse structure. Stacker cranes comprise the following components: masts, lower guide base or frame, upper guide base, hoisting mechanism and the mobile hoisting frame or cradle.

MECHANICAL COMPONENTS

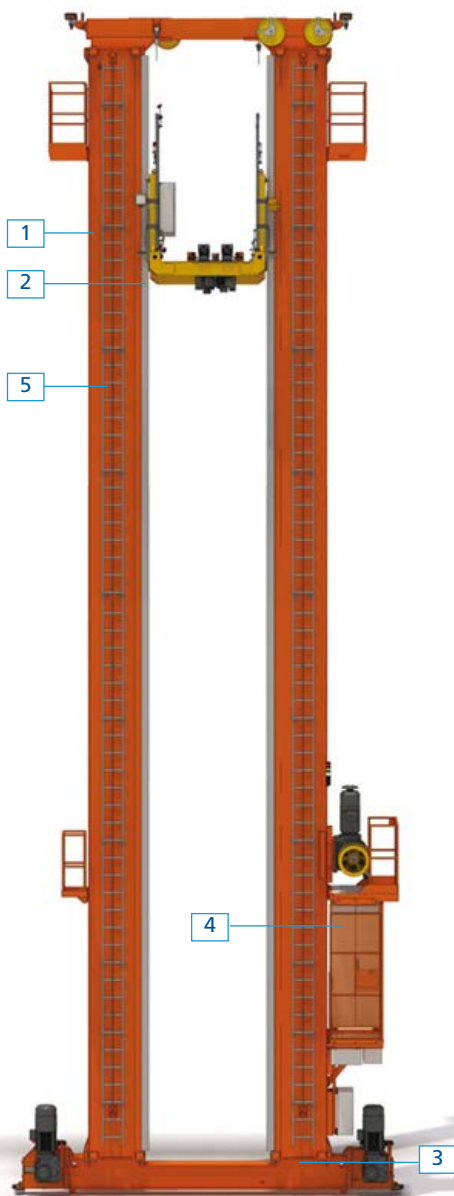

Masts

The masts can be made up of structural tubes or box girders. They are manufactured from heavy-duty steel sheet metal, specially shaped and welded together to form a rectangular-shaped box girder.

1. The box girder is reinforced inside by means of **lattice ribbing** fitted horizontally and diagonally, giving the mast greater resistance against torsion and bending. The double mast, double frame structure strengthens the stacker crane, ensuring it is very sturdy and stable when moving.
2. The masts come with **vertical rails** bolted on both sides that guide the hoisting cradle. These rails are made of heavy-duty calibrated rectangular profiles.

3. A **welded steel plate** is bolted at the base of the mast to the bottom frame. These machine-cut steel plates are welded to both ends of the mast, and then bolted to the top and bottom guide bases.
4. Under the hoisting assembly platform is a completely enclosed, secure control cabin, along with an electrical control panel.
5. Maintenance access is done via the emergency ladder installed along the mast's flank and comes equipped with a safety cable. All this equipment complies with current safety regulations.

The **MTB line** of twin-mast stacker cranes can be installed with a separate raisable maintenance booth to carry out maintenance tasks.



Lower guide base or frame

This box-shaped structure is made from welding profiles and steel sheet metal together, which are resistant to bending and torsion from the ribbing reinforcement welded inside it at regular intervals.

The drive wheel and freewheel heads are fastened to both ends of the lower frame with bolted, welded plates. The freewheel head allows the mast to be plumbed easily.

The drive wheel is fitted via a thermal process onto an axle that is supported on a set of bearings in these housings. The wheel is fitted or removed by dismantling the clamp fixing system.

A bevel gear reducer with hollow shafts is fitted onto this axle. It is secured by a torque arm, which is connected to an AC drive equipped with an electro-brake and an incremental encoder for blocking the speed regulation loop. The freewheel is mounted in the same way, but an elongated shaft is not needed to place the gear reducer.



Both the drive wheel and the freewheel have been designed with a flat machined rim made of cast steel, to ensure the safe, silent operation of the stacker crane. The running surface has been specially treated.

The longitudinal guidance system operates using contrast wheels positioned at both sides of the rolling rail and close to both the drive wheel and the freewheel.

Claws are bolted to the ends of the bottom frame to keep the wheels in contact with the surface of the rail, thus preventing the carriage from derailing during accidental collisions.

Upper guide base

The upper guide or frame is made of welded plates located at the top of the mast, which support the horizontal guide wheels on the top rail. These wheels are covered in a strip of Vulkollan® to dampen noise and vibrations that may be produced when the stacker crane is operating at high speeds.

The upper guide base is fitted with the lift cable's pulley system, which in turn is mounted on the axes by means of cylindrical roller bearings.

The stacker crane is designed so that any blow to the buffers is transmitted directly to the floor slab. In this way, any forces resulting from the machine crashing into the buffers are not transmitted to either the structure or the warehouse roof.



Hoisting operations

The function of the hoist mechanism is to raise the mobile frame vertically.

It consists of an AC motor designed to operate vector-controlled frequency inverters and is equipped with an encoder to close the speed control and braking loop.

This is coupled to a spiral bevel gear reducer. The side of the gears are specially treated and fitted with ground gear teeth. The bevelled units are also treated and lapped.

The drums are fitted on the shaft of the gear reducer. The lifting cables are wound around the drums, which are calculated according to European regulations. They are secured by means of a system of chocks, which adjust and dismantle easily.

Mobile hoisting frame or cradle

The purpose of the mobile hoisting frame (cradle) is to move the load and the cabin up and down, as well as to run the storage and retrieval cycles with the extendable forks fitted on the cradle.

An aluminium treadplate floor is fitted to the spaces between the two forks and the structure of the mobile frame. This is designed to support the weight of a person, while they carry out maintenance work.

Support rollers are fitted at the side of the frame next to the mast, which can be adjusted by cams. This enables the mobile frame to be adjusted horizontally, vertically and along the longitudinal axis of the aisle.

A built-in speed control mechanism is located on the side of the machine's mast. If the stacker crane exceeds the service speed, this mechanism acts on the profiles. No damage is caused to the vertical guide profiles by the chocks used.

Extraction systems

A determining factor in the performance of the stacker cranes is the unit load extraction system. Depending on of the requirements of each installation, the unit load is assigned custom parameters to get the best results.

The key parameter to take into account, in addition to the extraction speed, is the depth the fork can extend. Depending on the relationship between the static and dynamic capacity of each case, single, double and even triple-depth systems are used.

Depth refers to the number of pallets that can be placed in the rack on each side of the aisle. The term single-depth is used when a single pallet is placed on each side, and double-depth when two pallets can be placed on each side of the aisle.

In single-depth systems, priority is given to the speed of the system over the total storage capacity. Meanwhile, in double-depth systems, an excellent balance is achieved between storage capacity and handling speed.

Different extraction systems are available:

- Single-deep
- Double-deep
- Triple-deep
- Automatic Pallet Shuttle
- Roller conveyors



Single-deep telescopic forks

This horizontal handling mechanism enables unit loads to be deposited in or extracted from single-depth racking.

The telescopic fork is made up of two arms, joined by an articulated drive shaft and driven by a motor, which guarantees that both arms move uniformly.

The arms are made of high-quality steel for a robust system.

Double-deep telescopic forks

Comprising a horizontal handling mechanism, it helps deposit or extract unit loads in double-deep racking by means of telescopic forks.

The double-deep telescopic fork is made of the same components as its single-deep counterpart. However, it is run by two motors.

Triple-deep telescopic forks

Use these to insert three pallets across each side of the aisle on racks which have "top hat" pallet supports.

These forks are especially suited when increased storage density is key. The transport system in headers varies slightly, since pallets are warehoused and transported in the opposite direction.

FEATURES	SINGLE-DEEP	DOUBLE-DEEP	TRIPLE-DEEP*
Fork sizes for loads of 1,000 kg	1,300 mm	1,300 mm	1,900 mm
Fork sizes for loads of 1,500 kg	1,300 mm	1,400 mm	–
Outstretched fork	1,425 + 75 mm	2,825 + 25 mm	1,435 + 50 mm
Fork height & width	70 x 175 mm	75 x 185 mm	75 x 175 mm
Max. loaded deployment speed	30 m/min	42 m/min	40 m/min
Max. unloaded deployment speed	60 m/min	90 m/min	80 m/min
Unloaded/loaded acceleration	0.4 m/s ² – 0.8 m/s ²	0.5 m/s ² – 2 m/s ²	0.8 m/s ² – 1.2 m/s ²
Height difference between 1st and 2nd depth	–	150 mm	0 mm
Top hat crossbeam support	–	–	270 mm

*Check with our technical office.

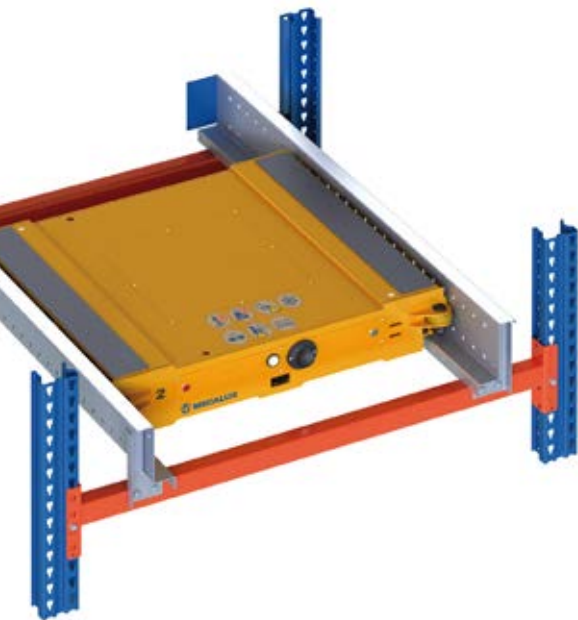

Pallet Shuttle

This mobile shuttle is fitted with a lifting system. It moves along rails under the loads inside the rack, enabling pallets to be loaded and unloaded in storage spaces up to 40 m deep.

The system makes dense storage possible in blocks of pallets with different widths, containers or cages.

Mecalux's Pallet Shuttle system incorporates the latest technological innovations, offering optimal performance.

- **High travel speeds:** 90 m/min when empty and 45 m/min when loaded.
- **Lithium batteries** that provide up to 10 hours of battery life, while working at full capacity.
- **Sensors** that mean pallets of all types can be detected and handled.
- **Battery compartments with quick connections** that eliminate the need for cables and speed up battery changes, so the work cycle runs uninterrupted.



Onboard conveyors

Ideal for feeding live channels comprising roller accumulations tracks via gravity. Fully automate the filling of gravity-flow channels.

- The **shuttle platform** is designed to carry pallets with deformations of up to 25 mm, as a maximum.
- **Compatible with Easy WMS,** Mecalux's warehouse management software, which helps eliminate errors.
- The **Wi-Fi control tablet** has a very intuitive, user-friendly interface.
- Includes advanced safety features, such as:
 - **Locking systems** that increase the contact between the Pallet Shuttle and the forks of the forklift.
 - **A positioning camera** to help the operator centre the shuttle between the rails (optional).
 - **A safety scanner on either side of the Pallet Shuttle** for safer rail access while the shuttle is in operation (optional).

ELECTRICAL COMPONENTS



Trilateral forks

Especially for use in installations with automated trilateral stacker cranes. These fulfil the needs of up to 15 m high automated pallet rack warehouses, without the need for an upper guide to be installed.

A rotating head allows pallets to be deposited and extracted from the racking in three different positions: from the front and either side.



Electrical cabinets

The stacker crane's onboard electrical cabinet is fitted to the rear of the front mast. The controls are laid out so the stacker crane can be safely operated as an individual unit from the platform.

The electrical connection to the cradle and the lift is made through sliding brushes fitted loosely to the cradle. The electrical power to the stacker crane can be cut thanks to a switch placed alongside the electrical cabinet and safety switches installed outside the aisle.

Energy recovery system

Optionally, an electronic module for feeding energy back into the network may be offered, allowing for power savings. The device is mounted on the stacker crane and connects the power supply from the converters' intermediate circuit. When the engines work as generators, most of their energy is returned to the customer's supply network for use by other elements that are powered in the same way.



Data transmission

Communication is established between the decentralised periphery terminals and the fixed PC or PLC, along with the adjustable-speed drives, through infrared optical communication systems (photocells). These have ranges of up to 240 m and a transmission speed of 1.5 Mbps, for working temperatures of down to -30 °C, if necessary.

The fixed photocells are placed at the end of the aisle, and the onboard ones are mounted on the lower guide. A set of photocells are fitted facing the cradle and the lower guide base for data communication between the onboard cabinet and the lifting cradle.

AISLE EQUIPMENT

The aisle equipment is made up of a bottom rail, a top guide rail, safety equipment, electrical supply, data transmission and positioning systems.



Bottom guide rail

An RN-45 rail, or the equivalent, is fastened to the concrete slab with support plates that have anti-vibration plastic insulation, all suitably separated according to the total mass, to properly distribute loads.

This fastening system is quickly and easily levelled, tolerating live loads and the effects of thermal variations.

A unique welding method is used between different sections to bear the previously mentioned situations.



Top guide rail

The top guide rail is made from either an HEA 120 profile or a structural tube. It is fixed to the rack's profiles by means of welded adjustment plates.

Contrast wheels apply lateral force to the top guide rail. Forces are at their highest when depositing and extracting the goods.



Positioning systems

When measuring the exact position of each axis, the most suitable system is selected:

- Beam detection
- Pallet push/pull control
- Laser rangefinder by default
- Absolute encoder

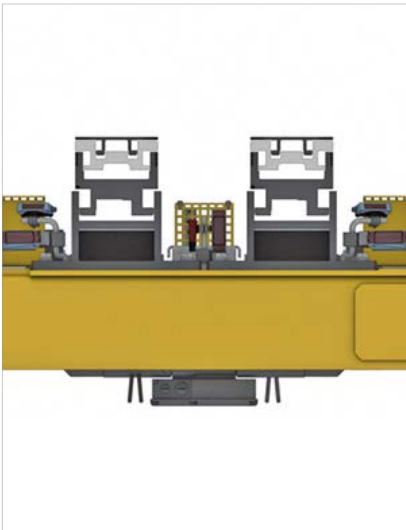

Crossbeam detection

Optical beam detection has improved, taking deflection into account to make depositing and extracting loads from the racks more precise.



Pallet push/pull control

This features analogue laser measurers to control the position of the pallets, thus keeping them from falling when being pushed or pulled.



Laser rangefinders

This optical equipment provides high-precision, 0.1 mm resolution distance measurements by reflecting the laser beam off at reflector at the opposite end of the aisle. These systems are used for controlling the travel and lift position. Measurements are direct and extremely reliable as they do not depend on a mechanical system, which could suffer from wear or wheel slippage.



Absolute encoders

Rotary devices with a codified value that is neither repetitive nor incremental, which produce an absolute and unique value for each angle of the shaft. They store the measured value, even when the machine has been disconnected. Commonly installed on telescopic forks and shuttles, they include anti-slip, anti-wear coupling devices and, in most cases, cover short distances.

Enabled electrical safety devices stop the stacker crane in the event the aisle is accessed.



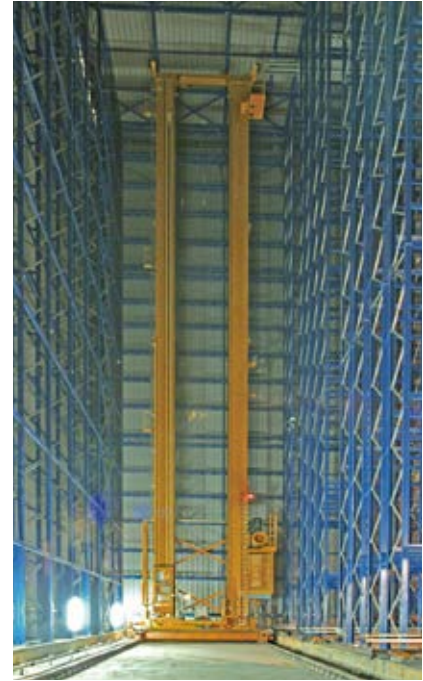

Aisle change systems

When the rotation of stored goods is relatively low, but the storage capacity must be high, it is not necessary for a stacker crane to be installed in every aisle. In these cases, a system is put in place to allow the stacker crane to move from one aisle to another.

- Curved tracks
- Transfer bridges

Curved tracks

In this system, it is the stacker crane which carries out the change manoeuvre from one aisle to another by means of a railway-type switch. A simple mechanical switch operation enables the destination aisle to be selected.

The main difference of these stacker cranes to standard ones is the inclusion of rotating wheels with side guide rollers, which are fitted in a special console.

The curved track switch system allows the stacker cranes to move at high speeds around these bends.

On bends and switches, the top guide is a rail designed to keep the top contrast wheels in place on the profile as they travel.

Transfer bridges

A transfer bridge is a machine that moves stacker cranes from one aisle to another. The stacker crane moves onto the bridge, where it is anchored and moved sideways to the destination aisle where the transfer is to take place.

This system enables work to be done at a higher speed inside the aisles, although it is less flexible in terms of changing aisles than the curved track system.

The installation of one system or another requires an exhaustive study of the factors involved in each case.



OPERATIONAL MODES

Mecalux stacker cranes can operate in automated, semi-automated or manual modes, as necessary.



Automated mode (without operator onboard)

Here, orders are executed after being sent through a communication photocell from the managing computer. In this mode, the following operations are carried out:

- Slotting,
- Extraction,
- Change of location,
- Correction of warehouse errors,
- Self-learning of the warehouse storage locations.

Semi-automated mode

Used for carrying out support functions, it includes:

- Automated access to a location, positioning the stacker crane automatically in the location ordered by the operator.
- Automated fork cycle: extracts or deposits a unit load automatically in the location indicated by the operator.
- Relocating goods.

Manual mode (with operator onboard)

Enables restricted access to all the parts of the stacker crane to carry out maintenance and repair work.

This operational mode requires visual control, i.e., it is always carried out with manually and at low speeds.



SAFETY EQUIPMENT



Onboard safety equipment

- **Ladders** with hinged landings.
- **Safety cable** (lifeline) to hook the maintenance operator's harness to when the ladder is in use to prevent falls. Each machine is supplied with a safety harness for working at great heights.
- **Safety railings** fitted onto all maintenance platforms to safeguard against possible accidents.
- **Maintenance platforms** fitted to positions on the stacker crane which are inaccessible from the ground level. These are accessible from the ladder or the cabin.
- **Lift for maintenance personnel** (optional), separate from the load lifting system.
- **Control cabin** fitted flush with the load frame.
- A **heated cabin (optional)**, on a lift or lifting frame, installed on stacker cranes operating in extreme temperature conditions.
- Certified **electronic control** with safety brake, preventing contact with the aisle end buffer.
- **Closed cabin** with manual controls for maintenance operations.
- **Mechanical over-speed stop system** for the cradle lift in case the lift cable breaks.
- **Magnetothermic protection** in the electric panels against overcurrents and overvoltage.
- **Heat protection** in the electric motors through anti-overcurrent temperature probes. Current limiters in the motors' power supply.
- **Overtravel lifting limiters** and monitoring of vertical speeds and fork extraction.
- **Optical distance photocell** installed in the cradle to confirm empty storage spaces and prevent pallets from falling.
- **Centring check system** to make sure the forks and loads are centred before being moved or lifted.
- **Built-in load calculation in the lifting cradle**, which blocks operations with overweight loads or ones with potential defects.
- **Red cable control** device that prevents the cradle from unravelling during descent.

Mecalux knows how important it is to ensure optimal, safe working conditions at work stations. So, it has equipped its stacker cranes with ergonomic and other safety equipment needed to perform work and maintenance operations as simple as possible.



Safety railing



Hand ladder and top maintenance platform



Aisle safety equipment

- **Emergency stop systems for stacker crane using standardised buttons** in the manual control positions and in specific areas of the installation.
- **Mechanical safety device** at aisle ends, consisting of rigidly fixated hydraulic buffers. The buffers are calculated to absorb the impact produced by the stacker crane when travelling at a nominal speed with the cradle loaded.
- **Overtravel limiters** to stop the stacker crane before it hits the end of the aisle.
- **Emergency stop areas** to control the maximum speed of an impact at the ends of the aisle.
- **Well-placed enclosures, signalling devices and emergency circuits** allow safe access to the aisles for maintenance work.
- **Button pad with integrated slotted key for aisle access.** Aisle access procedures are carried out in accordance with UNE-EN528 regulations.

Wireless safety signal transmission systems

An alternative to horizontal transmission systems using electrical lines, this one uses Fieldbus safety signals, which activate potential emergency stoppages of the installation.

It consists of an emitter located at one end of the aisle and a receiver mounted on board the stacker crane.

This system features a safety rating of 3, according to EN954-1 and a Performance Level (PL) = d, as per ISO 13849-1.

Velocity control

The control system manages the speed at which the machine moves. So, if an incident occurs, any impact against the end of the aisle does not take place at speeds of over 70%.

Core components

1. Hydraulic buffer
2. Button pad for aisle access
3. Safety barrier
4. Safety partitioning
5. Open/closed door detector with a single access key



2



4



5



Pallet conveyor systems

This conveyor system represents an ideal combination of stacker crane efficiency and the entry, dispatch and handling processes of unit loads. It involves a set of components designed to transport, accumulate and/or distribute goods to specific positions required by logistics operations.





CONTENTS

Conveying equipment	42
Roller conveyors	
Roller accumulation conveyor	
Conveyor for half-pallets	
Ground-level roller conveyors	
Two-strand chain conveyors	
Chain conveyors with more than two strands	
Mixed transfers with rollers and chains	
Turntables (rollers or chains)	
Transfer car	
Live ground level exits	
Entry/exit chain conveyors	
Control systems	
Pallet entry checkpoint	
Pallet lifts	
Conveyor protectors	
Pallet doublers	
Automated truck loading and unloading system	
Pallet stacker/unstacker	
Layer pickers	
Electrified monorail systems	



Mecalux supplies a wide range of devices for transporting unit loads. The company has focused on standardising its measurements and components as much as possible, with the aim of facilitating the production, assembly and start-up of installations. All of this results in a reduction in delivery times and installation costs.

CONVEYOR SYSTEMS

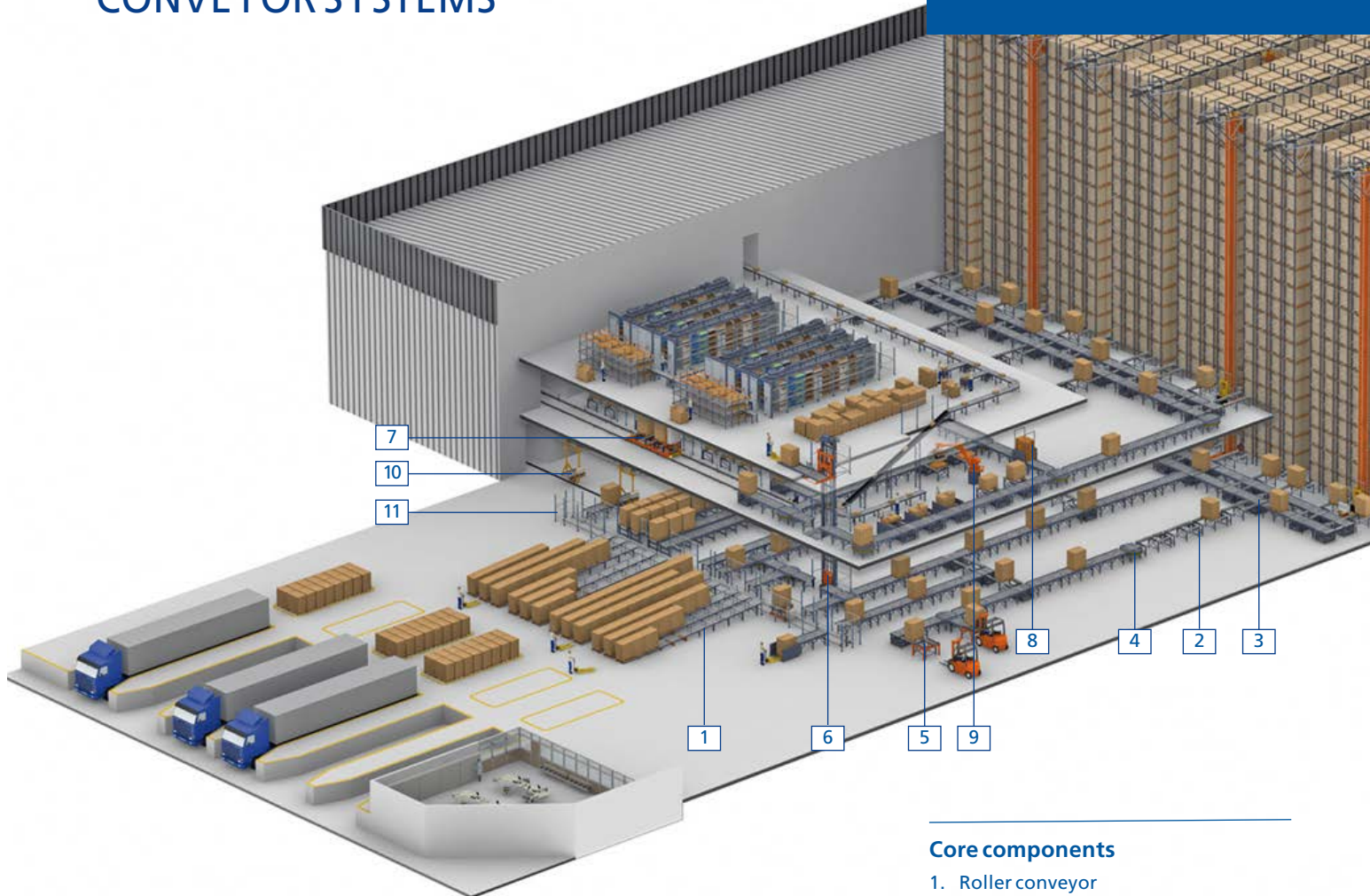

Core components

1. Roller conveyor
2. Chain conveyor
3. Mixed transfer with rollers and chains
4. Turntable conveyor
5. Chain conveyor at the warehouse entry/exit

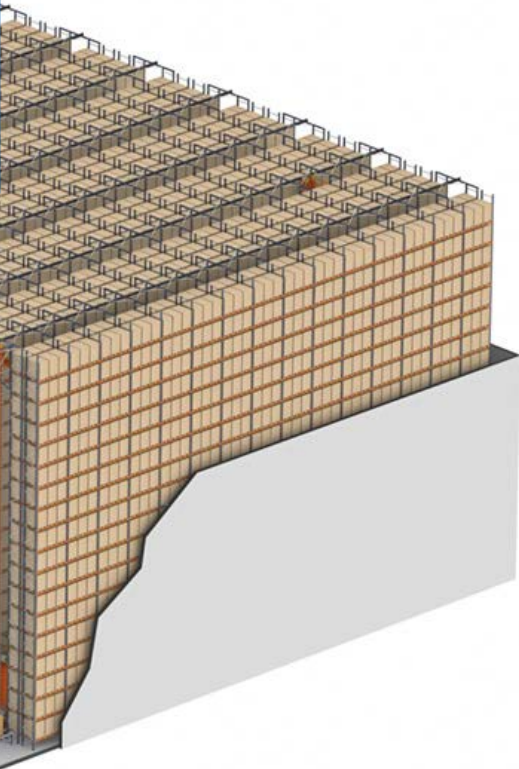

Roller conveyors

Transfers pallets in the same direction as the skids on the the pallet.

This is the most suitable device for transporting pallets over long distances, when pallets are being transported in a down-aisle direction. Moreover, it adapts to different pallet widths. Consequently, the most appropriate guides are configured for each format.

It is designed to transport individual heavy-duty loads. Likewise, it allows configurations with sequential batches of more than one load and up to 4,000 kg.

Its sturdy design provides excellent reliability in all work environments. The working conditions described in the technical data table below reflect those of a standard model. However, these values can be extended, if suitable protective devices are fitted.

6. Pallet lift
7. Transfer car
8. Pallet stacker / unstacker
9. Layer picker
10. Electrified monorail system
11. Safety and protection devices

TECHNICAL DATA: Roller conveyors

Pallet width	800 / 1,000 / 1,200 mm
Max. unit load weight	1,500 kg
Min. length	1,340 mm
Max. length	5,348 mm
Standard conveyor heights	600 / 900 / 1,100 mm
Roller diameter	80 mm
Conveyor speeds	10-20 m/min
Brake	Optional
Mechanical stop at endpoint	Optional
Pallet guide	Guide wheels
Working conditions	Max. humidity: 70%
	Ambient temperature: 0 °C to 40 °C
	Freezer temperature (optional): -30 °C to 0 °C



Roller accumulation conveyor

A linked roller system can be added to decrease the price of a conveyor system, which. With the help of a single motor, it allows several pallets accumulate, reducing material and maintenance costs.

These types of conveyors can handle up to four Euro pallets and their speed is limited to 7 m/min.

TECHNICAL DATA: Roller accumulation conveyor

Pallet width	800/1,000/1,200 mm
Max. unit load weight	1,000 kg
Available length	No. of pallets x 1,352 mm
Standard conveyor height	600 mm
Roller diameter	80 mm
Speed	7 m/min
Bi-directional movements	Optional
Pallet guide	Guide wheels
Working conditions	Max. humidity: 70% Ambient temperature: 0 °C to 40 °C Freezer temperature (optional): -30 °C to 0 °C

Conveyor for half-pallets

When the unit load is the size of a half-pallet (600 x 800 mm), chain conveyors must be fitted with two additional central chain strands to convey two half-pallets in parallel.

When half-pallets are moved on rollers, the rollers must be smaller in diameter and the space between them must be narrower.



TR05 (rollers for half-pallets)

Half-pallets slide over 60 mm diameter rollers with a smaller distance between each one, as compared to a Euro pallet conveyor.



TC05 (chains for half-pallets)

Half-pallets move along the chains and are transported two by two in parallel, occupying the entire width between the exterior chain axes.



TM05 (mixed transfer for half-pallets)

This conveyor can transfer two half-pallets grouped in pairs.

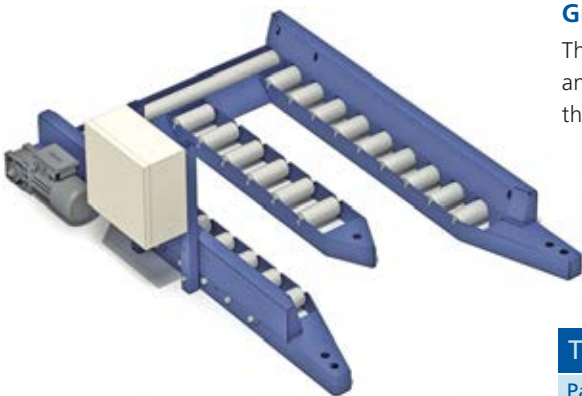

Ground-level roller conveyors

This conveyor allows ground level loading and unloading with a pallet truck, without the need for a forklift.

When used at the entry and exit points of the system, the roller level is set at 80 mm. The load is raised automatically until it reaches the same level as the rest of the transport system, thus facilitating its continuous movement.

An inductive loop sensor has been incorporated for safety.

TECHNICAL DATA: Ground-level roller conveyors

Pallet width	800/1,000/1,200 mm
Max. unit load weight	1,500 kg
Available length	1,520 mm
Conveyor height	80 mm
Roller diameter	60 mm
Standard speed	10-20 m/min
Pallet guide	Exterior or lateral collars
Working conditions	Max. humidity: 70% Ambient temperature: 0 °C to 40 °C Freezer temperature (optional): -30 °C to 0 °C



Two-strand chain conveyors

This pallet conveyor transports pallets perpendicular to their skids. This is the perfect addition to the roller conveyor, as the combination of both devices enables 90° or 180° turns, facilitating the formation of circular routes and conveyor circuits, which can be very useful for certain requirements. The conveyor can have 2, 3 or 4 chain strands, according to the characteristics of the load.

The environmental conditions described in the technical data table below reflect those of a standard model. However, these values can be extended, if suitable protective devices are fitted.

TECHNICAL DATA: Two-strand chain conveyor

Pallet width	800/1,000/1,200 mm
Max. unit load weight	1,500 kg
Available length	1,302/2,006/2,710 mm
Standard conveyor height	650/950/1,150 mm
Speed	10-20 m/min
Mechanical stop at endpoint	Optional
Pallet guide	Optional channelers
Working conditions	Max. humidity: 70%
	Ambient temperature: 0 °C to 40 °C
	Freezer temperature (optional): -30 °C to 0 °C



Pallet conveyor systems



Three-strand chain conveyors



Four-strand chain conveyors

Chain conveyors with more than two strands

When the quality of a pallet is poor, a third strand must be installed on the conveyor to prevent any further deformation or warping of the pallets. This option can also be employed to transfer pallets lengthwise for short distances.

If half-pallets are to be moved on the conveyor, four strands will be installed to ensure the proper flow of the deposited pallets.

TECHNICAL DATA: Chain conveyor with more than two strands

Pallet width	3 strands: 800 / 1,000 / 1,200 mm 4 strands: 800 mm (half-pallets)
Max. unit load weight	3 strands: 1,500 kg 4 strands: Full-pallet 1 x 1,500 kg - Half-pallet 2 x 500 kg
Available length	1,302 / 2,006 / 2,710 mm
Standard transport height	650 / 950 / 1,150 mm
Speed	10-20 m/min
Mechanical stop at endpoint	Optional
Pallet guide	Optional channelers
Working conditions	Max. humidity: 70% Ambient temperature: 0 °C to 40 °C Freezer temperature (optional): -30 °C to 0 °C



Mixed transfer with rollers and two chain strands



Mixed transfer with rollers and three chain strands

Mixed transfers with rollers and chains

This conveyor has both rollers and chains, enabling 90° and 270° changes in direction. The rollers are fitted into a bed and the chains are placed on a lifting frame. The height of the chain conveyor is always 50 mm higher than the rollers, to facilitate proper operations.

Combining both components into a single unit is the best way to incorporate direction changes into the circuit.

As is the case with chain conveyors, mixed transfers can be fitted with three or four chain strands, if necessary.

There is a built-in hinged bumper to guarantee the proper positioning of the pallet before the transfer takes place.



Mixed transfer with rollers and four chain strands



TECHNICAL DATA: Mixed transfers with rollers and chains

Pallet width	2/3 strands: 800/1,000 mm – 4 strands: 800 mm
Maximum weight of unit load	2/3 strands: 1,500 kg – 4 strands: full pallet 1 x 1,500 kg – half-pallet 2 x 500 kg
Available length	2/3 strands: R: 1,350 – C: 1,275 / 1,475 mm – 4 strands: R: 1,350 – C: 1,275 mm
Transport height (roller-chains)	2/3/4 strands: R: 600 – C: 650 mm/R: 900 – C: 950 mm/R: 1,100 – C: 1,150 mm
Roller diameter	80 mm
Conveyor speeds	10-20 m/min
Working conditions	Max. humidity: 70% Ambient temperature: 0 °C to 40 °C Freezer temperature (optional): -30 °C to 0 °C



Turntable conveyor (rollers or chains)

This roller or chain conveyor can turn loads, which enables the unit loads to be transferred between unaligned conveyors.

The roller or chain turntable allows can position a pallet at any angle with respect to the input flow.



Roller turntable (TGR)



Mixed transfer turntable (TMG)



Chain turntable (TGC)

TECHNICAL DATA: Turntable

	TGR	TMG	TGC
Pallet width	800/1,000/1,200 mm	800/1,000/1,200 mm	800/1,000/1,200 mm
Max. unit load weight	1,500 kg	1,500 kg	1,500 kg
Outer diameter	1,730/1,830 mm	1,850 mm	1,730 mm
Transport height	600/900/1,100 mm	650/950/1,150 mm	650/950/1,150 mm
Roller diameter	80 mm	80 mm	–
Conveyor speed	up to 20 m/min	up to 20 m/min	up to 20 m/min
Time needed to turn a min. 90°	4 s	–	4 s
Working conditions	Max. humidity: 70% Ambient temperature: 0 °C to 40 °C Freezer temperature (optional): -30 °C to 0 °C		



Transfer cars

Single-load transfer car

Designed to transfer loads in a cross-aisle direction, this transfer car permits top workflows thanks to its high travel speed.



Twin-load transfer car

Unlike the previous transfer car, use the configurable parameters of the twin-load model to customise the distance between loads according to your installation's requirements. As such, the part which joins the two frames may vary according to this distance. It has a high load capacity (2 x 1,000 kg).

TECHNICAL DATA: Single-load transfer car

Conveyor base	Euro pallet 800 / 1,000 / 1,200 mm Half-pallet 800 x 600 mm
Max. pallet load	1,500 kg
Loaded transport speed	100 m/min
Unloaded transport speed	140 m/min
Positioning system	Rangefinder
Communication system	Infrared photocell
Power supply	Sliding contacts
Working conditions	Max. humidity: 70% Ambient temperature: 0 °C to 40 °C Freezer temperature (optional): -30 °C to 0 °C

TECHNICAL DATA: Twin-load transfer car

Conveyor base	Euro pallet 800 / 1,000 / 1,200 mm Half-pallet 800 x 600 mm
Max. pallet load	3,000 kg
Loaded transport speed	100 m/min
Unloaded transport speed	140 m/min
Positioning system	Rangefinder
Communication system	Infrared photocell
Power supply	Sliding contacts
Working conditions	Max. humidity: 70% Ambient temperature: 0 °C to 40 °C Freezer temperature (optional): -30 °C to 0 °C



Pallet conveyor systems

Live ground level exits

As standard gravity flow accumulation system, it does not require motors to move pallets along its surface. The suitable inclination, along with the rollers and speed regulators create a buffer where pallets can accumulate.

Set up in loading docks, use them to prepare outgoing lorry loads. Loading can be automated, if conveyors or shuttles are used, or manual, using forklifts.

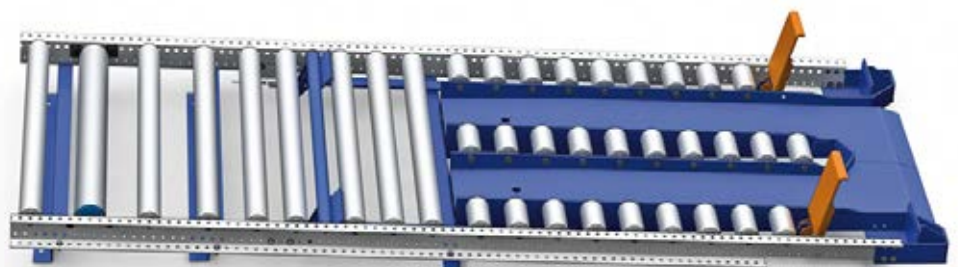



Entry/exit chain conveyors

As a rule, a pallet is always picked up by the forks along its shorter edge to be deposited in the automated warehouse. Chain conveyors need to be set up at the entry and exit points of these warehouse aisles to optimise the installation's capacity.

Similar to the chain conveyor described on previous pages, this conveyor's length and strands may vary according to accumulation requirements.



Control systems

The automated operations of all elements within an automated warehouse are controlled by electrical and electronic systems. This equipment is set up inside electrical cabinets with control mechanisms and motor protection, as well as output electrical components for managing conveyor speeds. In turn, these cabinets are run by PCs or PLCs to ensure optimal facility operations.

A joint decision made with the client determines the location of these components and boxes for the best possible accessibility and protection.

Pallet entry checkpoint

The pallet entry checkpoint is an important part of the conveyor system. Here, the size of unit loads are measured to see that they meet installation parameters. It is the first control point on the conveyor system and includes a barcode reader to identify and register the product in the WMS. To guarantee proper pallet transport and storage, two devices are installed to control the condition and quality of the pallet base, on which it is carried. One monitors the slots where the forks are inserted, and the other controls the skids the pallet rests on when in the rack.

The following checks must be carried out as a standard practice:

- Load collapse control.
- Load width control.
- Height control.
- Excess weight control.
- Identification with barcode reader.

If an irregularity is detected, the unit load is rejected and the operator panel displays the defect to recondition.



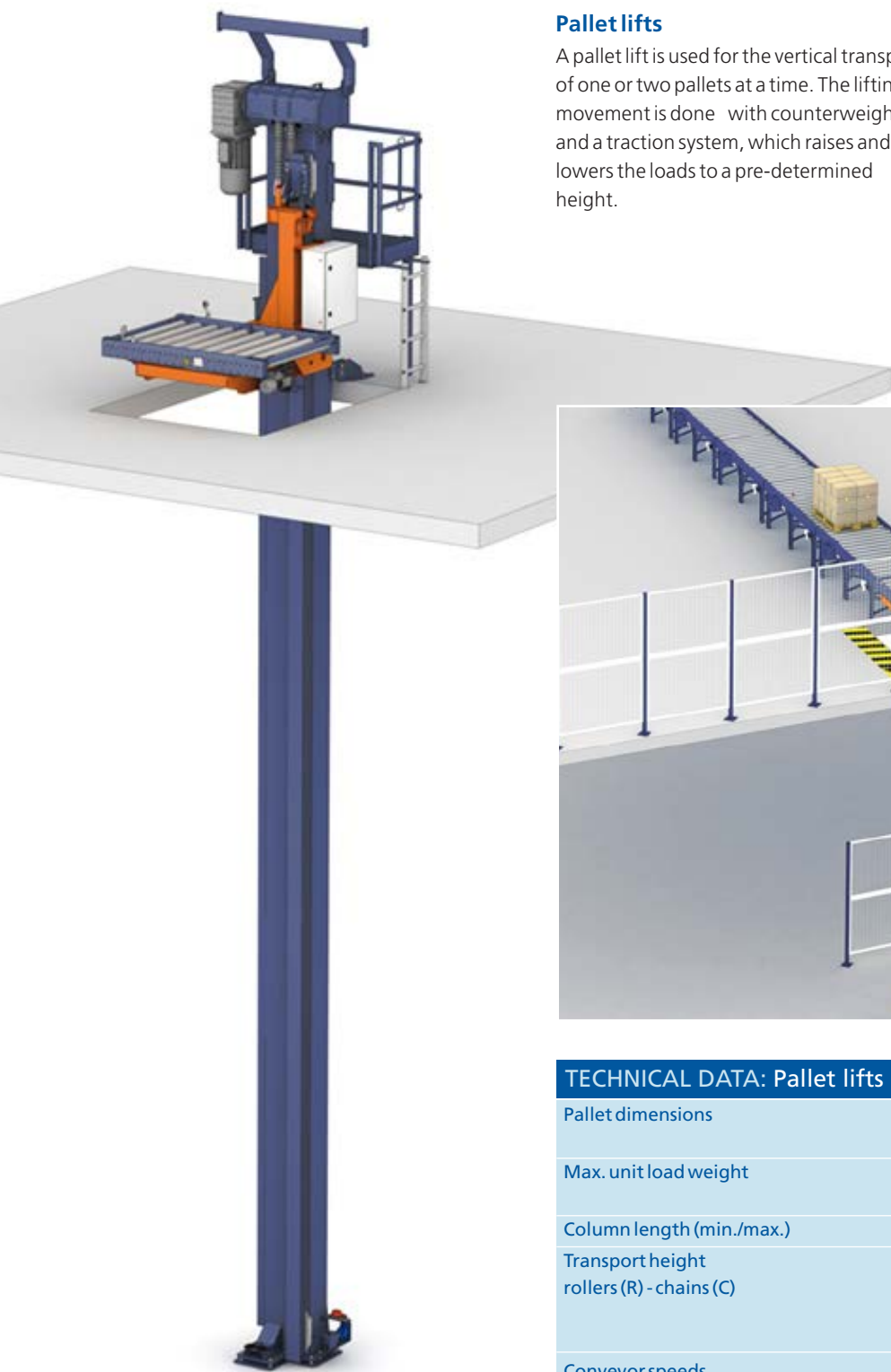

Pallet lifts

A pallet lift is used for the vertical transport of one or two pallets at a time. The lifting movement is done with counterweights and a traction system, which raises and lowers the loads to a pre-determined height.

This component is used when loads need to be transported vertically, with a minimum height of 500 mm and a maximum of 35,000 mm.

The conveyor leading to the lift must be the same type as the lift's entry/exit unit.

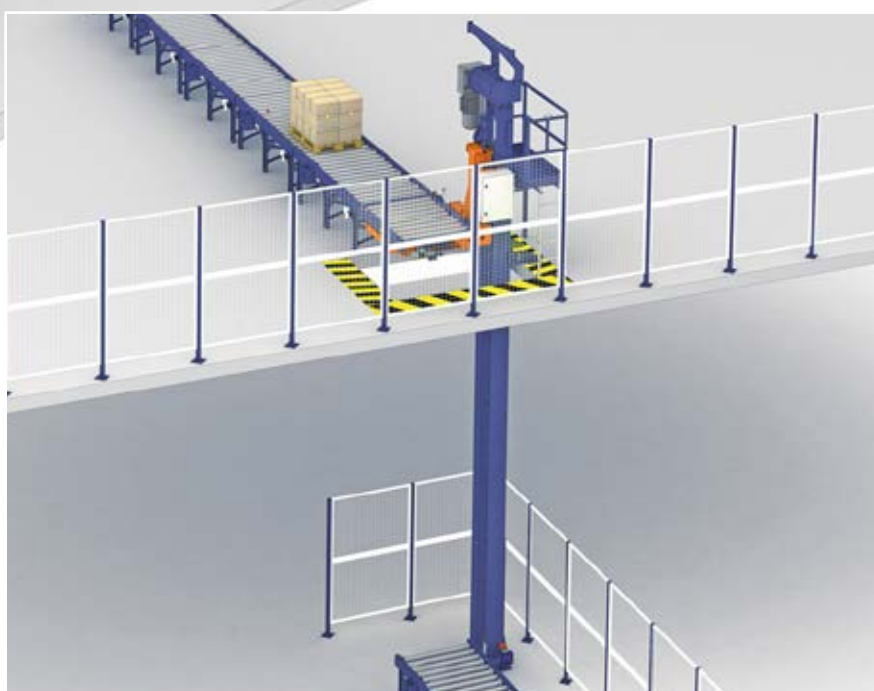

TECHNICAL DATA: Pallet lifts

Pallet dimensions	Pallet (800 / 1,000 / 1,200 mm) Half-pallet (800 x 600 mm)
Max. unit load weight	1,500 kg (pallet 800 / 1,000 / 1,200 mm) 500 kg (half-pallet 800 x 600 mm)
Column length (min./max.)	4,150/35,000 mm
Transport height	R: 500 – C: 550
rollers (R) - chains (C)	R: 600 – C: 650 R: 900 – C: 950 R: 1,100 – C: 1,150
Conveyor speeds	20 m/min
Max. lift speed	80 m/min (1,000 kg) – 60 m/min (1,500 kg)
Lift acceleration	0.7 m/s ² (1,000 kg) – 0.5 m/s ² (1,500 kg)
Conveyor types onboard	Rollers/chains
Vertical speed regulator	Variable frequency drive
Working conditions	Max. humidity: 70% Ambient temperature: 0 °C to 40 °C Freezing temperature (optional): -30 °C and 0 °C



Pallet conveyor systems



Conveyor protectors

Metal protectors are installed on the conveyors to prevent damage to the entry and exit conveyors from forklift loading and unloading. They are anchored to the floor and separated from the conveyor. So, if they are hit by the forklift, the system will continue to work properly.



Entry protectors



Exit protectors

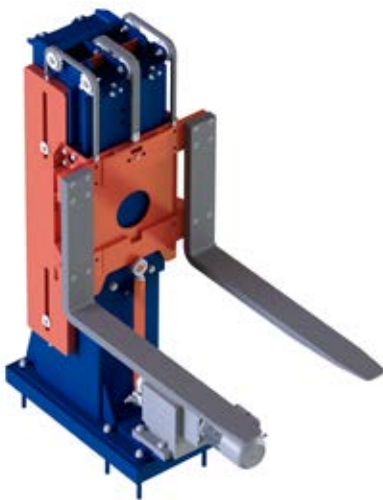
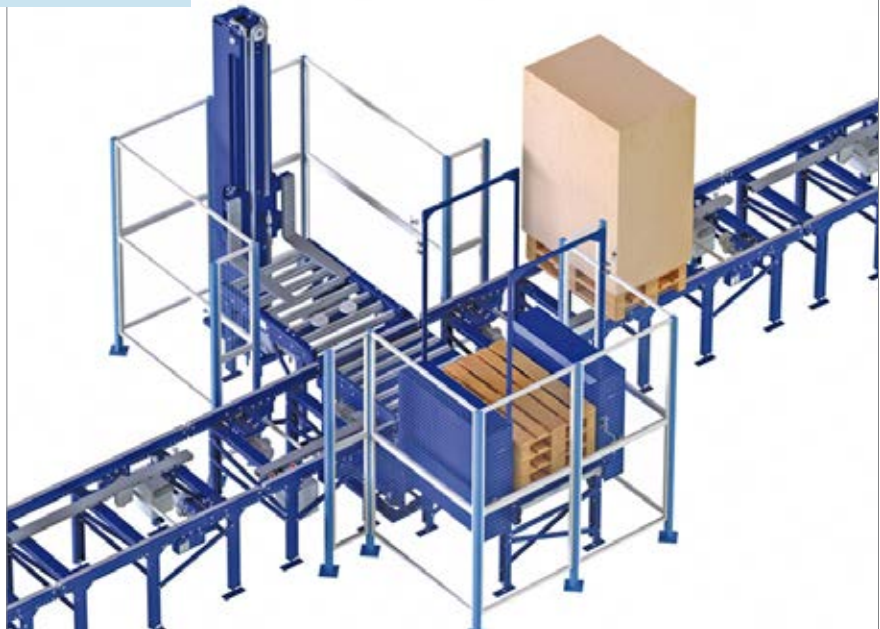

Full pallet stacker

When bad quality pallets move around the conveyor system, or do not meet the facility's requirements, a slave pallet is inserted underneath. The reverse operation is performed to remove the pallet, by taking out this extra pallet that was inserted when the load entered the warehouse.



Full load stacker

This doubler is used when several layers of products need to be mounted on top of each other to make up a full pallet.

TECHNICAL DATA: Full pallet stacker

Palet width	800/1,000/1,200 mm
Max. unit load weight	1,000/1,500 kg
Transport height rollers (R) - chains (C)	R: 600/900/1,100 mm C: 650/950/1,150 mm
Lift height	200/205 mm
Working conditions	Max. humidity: 70% Ambient temperature: 0 °C to 40 °C Freezer temperature (optional): -30 °C to 0 °C

TECHNICAL DATA: Full load stacker

Pallet width	800/1,000/1,200 mm
Max. unit load weight	750 kg
Transport height rollers (R) - chains (C)	R: 600/900/1,100 mm C: 650/950/1,150 mm
Lift height	1,255/1,755 mm
Working conditions	Max. humidity: 70% Ambient temperature: 0 °C to 40 °C Freezer temperature (optional): -30 °C to 0 °C

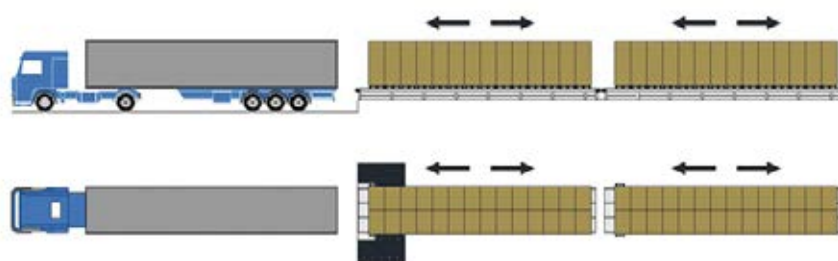

Automated truck loading and unloading system

Use this system to load and unload lorries automatically. The system requires:

- A fixed set of equipment in the loading dock.
- A fixed set of equipment in the unloading dock.
- A semitrailer equipped with an onboard conveyor system.

Loading and unloading dock

Made up of six sections, each dock includes a beam on which the guided duplex-type conveyor chain moves. The docks are a maximum 12 m long and only differ in the direction the conveyors move.

Semi-trailers

Each trailer is installed with a motorised conveyor with six chain strands.

Power is supplied from a socket, located on the exterior of the loading dock. This system guarantees transfer operations from the dock conveyor to the vehicle and prevents blockages and wear on the trailer.

An exterior centring systems correctly positions and supports the trailer during the transfer.

System reliability and safety

The whole installation is protected against possible blows and scrapes, which could stop it from operating properly.

Benefits of the system

- Mass handling of goods.
- Large time savings during loading and unloading.
- Elimination of accidents during load handling.
- Reduction of personnel and material handling equipment.
- Forklift may be used (according to type).
- Able to move a load of up to 32 t.

TECHNICAL DATA: Automated loading and unloading system

Length	12,000 mm
Total width	2,400 mm
Conveyor height	650/950 mm
Max. unit load weight	1,000 kg
Max. load capacity	32,000 kg
Load/unload time for 12 m semitrailer	4.5 min



Pallet stacker/unstacker

Automated conveyor systems that need empty pallets to be collected or distributed use pallet stackers.

Through a system of electromechanical telescopic lifting forks, the stack of empty pallets is placed on top of a new pallet. Then, the entire stack is lifted. The same device can reverse the process and unstack the pile. By placing the pile on the conveyor and lifting the remaining pallets off the one below, the unstacker frees up the latter for transport.

Use these elements to configure units that distribute empty pallets to order prep stations, or stack leftover pallets at these same stations.

TECHNICAL DATA: Stacker/Unstacker

Max. stacking capacity	15 pallets
Transfer speed	10-20 m/min
Lengths available	1,340/1,302 mm
Transport height range	Rollers: 550 to 1,100 mm Chains: 600 to 1,150 mm
Standard transport height	Rollers: 600/900/1,100 mm Chains: 650/950/1,150 mm
Working conditions	Max. humidity: 70% Ambient temperature: 0 °C to 40 °C Freezer temperature (optional): -30 °C to 0 °

Layer pickers

A layer picker is a machine which moves a whole layer of unit loads. So, when dividing a single-product pallet, the layer picker removes the units layer by layer and deposits them on top of other pallets being sent to the dispatch area.

Two types of layer pickers are available:

1. **Vacuum stackers:** a complete layer is removed via a turbine suctioning system, letting you handle products of different shapes and sizes.
2. **Suction cup / claw stackers:** a complete layer is taken by suspending the product from multiple suction cups or grip claws. This system is designed to create compact, homogenous product layers.

TECHNICAL DATA: Layer pickers

Max. load height (with pallet)	2,500 mm
Max. layer weight	300 kg
Max. travel speed	120 m/min
Lifting speed	30 m/min
Max. number of unstacking posts	20
Max. travel length	25 m
Max. incoming cycles	25 pallets/hour
Max. outgoing cycles	150 layers/hour



Electrified monorail systems

An alternative to conveyors that uses individually run trolleys that move along an I-shaped rail. The rail is suspended from the warehouse ceiling or fastened to the floor by means of gantry structures.

Advantages:

- **Easy to use.**
- **Highly reliable** when faced demanding workflows.
- **Very adaptable** to each plant's specific needs.
- **Minimal effects on the plant's operations from installation and maintenance.**
- **Cost-effective system:** only operates when a load is being transported .
- No physical barriers.
- **Trolleys are autonomous,** permitting them to be removed from the system individually.

The design of the electrified monorail can be adapted to each company's work areas with switches, turn-rounds, entries and exits.

The electrified monorail system helps balance overall production cycle times.

Core components

1. Entry and exit turn-off
2. Three-rail switch
3. Parallel switch
4. Turntable
5. Turntable with two rails

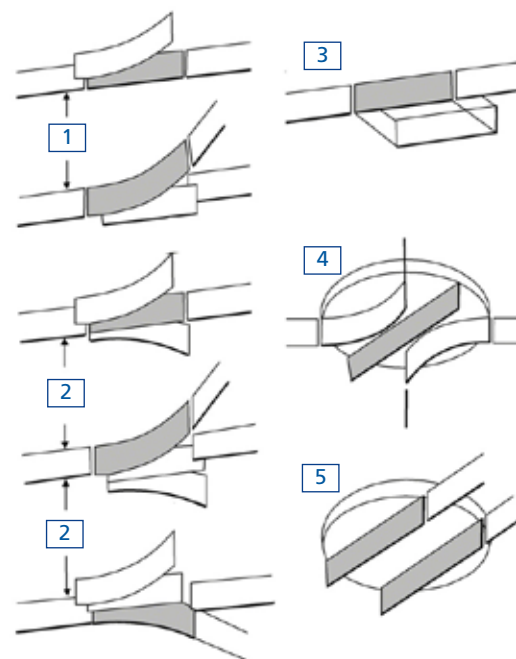

Different available rail switches



Basic construction features

Centralised control devices for the electrified monorail system

These devices control the electrified monorail by means of a destination code from the departure point to the point of arrival. The most suitable route is always used, and empty vehicles are distributed at different loading points around the circuit.

Automotive vehicles with load-carrying equipment

The same engine is used in both single and double-load vehicles and consists of a cross-tie with several hooks, depending on the load being transported. A single multi-directional gear motor moves the vehicle along the electrified monorail. Several types of equipment are used for transport: fixed, mobile and suspended.

An onboard roller conveyor can be fitted, or the system can be adapted with pick-to-light devices, for example.

Electrified circulation rail

The rail delivers power to the motors through copper leads.

Movement control without sensors

Communication along the copper rails enables the position of each trolley to be known at all times and removes the need for external detection devices.

Rail switches, crosses and turn-offs

A range of devices make rail switches and short-cuts possible, and allow maintenance areas to be set up.

Diagnosis workstations

It is highly recommended to use workstations with automatic diagnostics to inspect each new phase of transport and prevent problems with flows. The station also detects breakdowns and controls the level of wear and tear of critical components.

Additional constructive features

Vertical lifts

Lifts enable movements between the different levels within the same route, thus enabling vertical transport.

Safety measures

Maximum protection is offered by fitting safety mesh under the rails.

TECHNICAL DATA: Electrified monorail system

Max. Load capacity	1,500 kg
Speed with load	100 m/min
Speed without load	120 m/min
Conveyor types on board:	Rollers/Chains
Working conditions	Max. humidity: 70%
	Ambient temperature: 0 °C to 40 °C
	Freezer temperature (optional): -30 °C to 0 °



Stacker cranes for boxes

A standard automated storage system for boxes or trays, which integrates racks, machinery and a warehouse management software into a single product.

The extraordinary versatility of the system enables it to be integrated into any production or storage process.





CONTENTS

Stacker cranes for boxes	64	Aisle equipment	75
Single-mast stacker cranes		The bottom rail	
Twin-mast stacker cranes		The top rail	
Mechanical components	70	Positioning systems	
Lower guide base		■ Precise positioning	
Mast		■ Absolute encoder	
Upper guide base		Aisle change systems	
Cradle or mobile hoisting frame		Modes of operation	78
Hoisting operations		Automated mode	
Extraction systems		Semi-automated mode	
Electrical components	74	Manual mode	
Onboard electrical cabinet		Safety equipment	79
Safety controls		Aisle end safety	
Data transmission		Safety devices	



STACKER CRANES FOR BOXES

The automated warehouse for boxes consists of a central aisle, along which a stacker crane travels, and two laterally-built racks to store boxes or trays. The picking and handling area features conveyors and is positioned at one end or at the side of the racking. Here, the stacker crane deposits the load extracted from the rack. The conveyors then take the box to the operator. Once they have finished the job, it is returned to the stacker crane, which then places it back in the racking.

The whole system is controlled by a management software package, which registers the location of all the materials in the warehouse and keeps a real-time inventory.

The extraordinary versatility of the system enables it to be integrated into any production or storage process.

Main features:

- Optimal use of space through high-density storing.
- Quick access to loads.
- Real-time inventory with our state-of-the-art computer system.
- Operate 365 days a year.
- Increased productivity compared to standard product management.

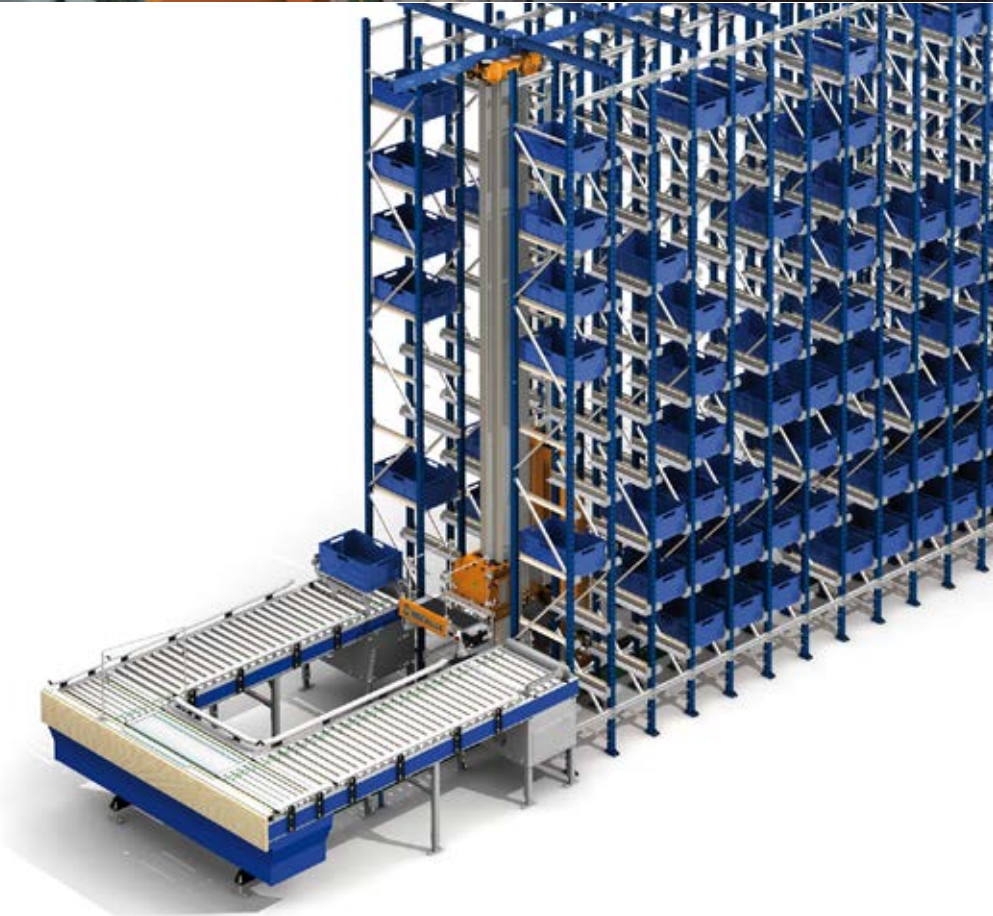

- A totally safe load handling process, as operators are not required within the storage area.
- Protection of the load and elimination of unwanted, untraceable product losses.
- Reliable and easy to use.
- Reduced maintenance costs.
- Particularly effective for companies with demanding order preparation processes.
- Applicable in most sectors: pharmaceuticals, laboratories and cosmetics, public administration, automotive industry, DIY, electrical appliances, telecommunications, etc.
- Reduce the time needed to prep and dispatch orders.
- Quick return on investment.
- Environmentally friendly.
- Fewer specialised operators needed.

Stacker cranes

A robot in tasked with locating and removing boxes from the racks, as well as carrying and depositing them on the conveyor at the front of the warehouse.

The crane can perform two movements: down the aisle along a rail and vertically, to place boxes on the different storage levels, as required. Cross-aisle movements to extract and deposit boxes are performed using the extraction system located in the lifting cradle.

Components of the stacker crane

This robot, which can handle and store goods, consists of various elements that form an integrated unit. It moves along rails embedded in the floor, with its upper section guided by a profile attached to the racking.

The correct position of the stacker crane is controlled using laser rangefinders. Communication is done via wireless infrared devices (communication photocells). It uses open fixed lines and sliding plates as its power supply.



Core components

1. Upper guide base
2. Mast
3. Lower guide base
4. Onboard electrical cabinet
5. Cradle and extraction system
6. Travel components
7. Lifting components
8. Laser rangefinder
9. Wireless communications equipment
10. Power supply cable
11. Lower rail
12. Upper guide rail
13. End-of-aisle stop

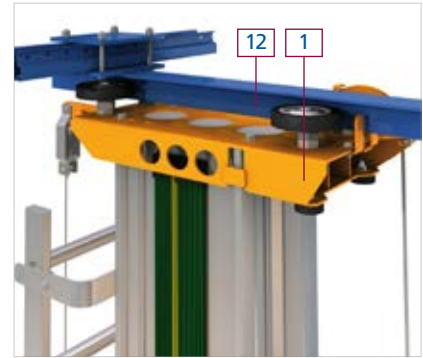

Upper guide base (1) and upper guide rail (12)

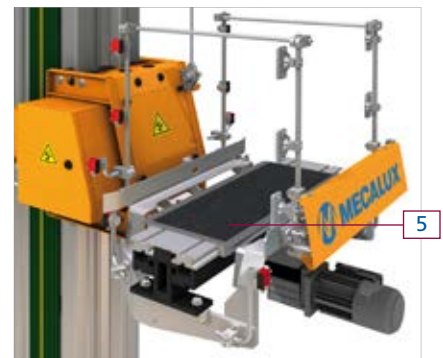

Cradle or mobile lifting frame (5)



Lower guide rail (11), power supply (10), and hydraulic end-of-aisle stop (13)



Lower guide base (3), lifting components (7), and rangefinder (8)



Single-mast ML stacker cranes for boxes

Developed and manufactured by Mecalux, the ML50 light-duty series and the ML100 medium-duty series of single-mast miniload stacker cranes are designed to achieve high productivity levels and manage two types of boxes:

- **600 mm x 400 mm Euro boxes**

These stacker cranes are capable of managing plastic, cardboard or metal boxes, and rigid trays with a variable box and load height.

- **800 mm x 600 mm Euro boxes**

Mecalux can organise the movements of any type box or tray, when a higher capacity box is required. As is the case with lower volume boxes, heights are available to suit the needs of the warehouse.



The ML50 series

These vehicles are characterised by an aluminium mast that can handle up to 50 kg at a height of 12 m. Basically, this range is designed for high productivity.

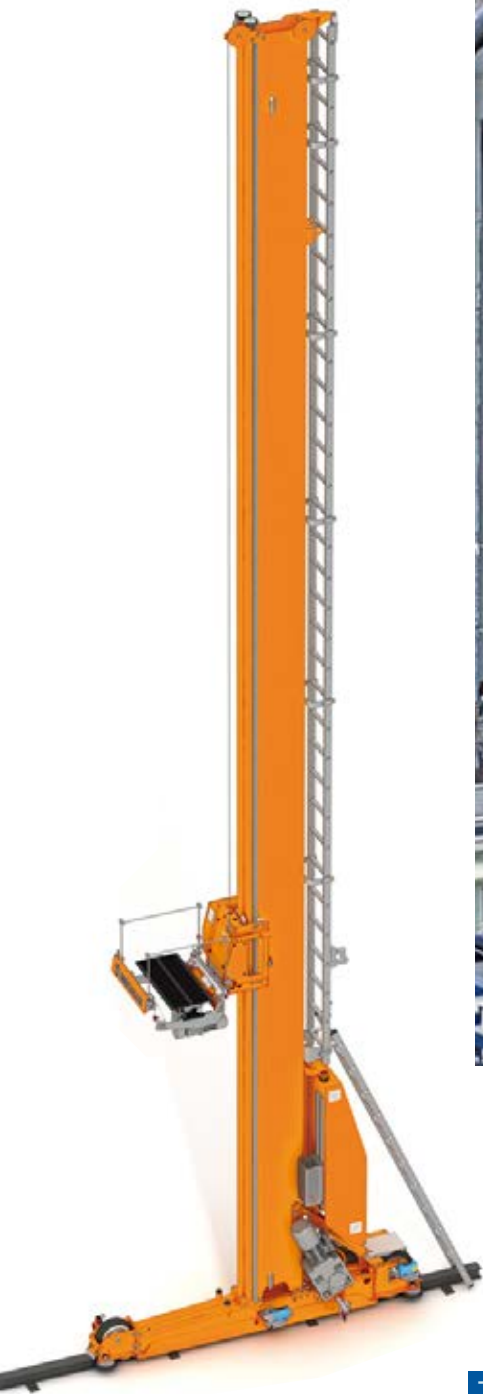

Stacker cranes for boxes

The ML100 series

These vehicles have a maximum height of 12 m, and can carry up to two 50 kg boxes.

TECHNICAL DATA: Single-mast ML stacker cranes for boxes		
Features	ML50	ML100
Load capacity	Up to 50 kg	Up to 100 kg
Max. height	12 m	12 m
Unit load	Eurobox 1 pc x 600 x 400 mm	Eurobox 2 pcs x 600 x 400 mm / 1 pc x 800 x 600 mm
Double-deep telescopic forks	Yes	Yes
Twin-load extraction fork	No	Yes
Max. travel speed (V_x)	180 m/min	200 m/min
Max. travel acceleration (a_x)	1 m/s ²	0.7 m/s ²
Max. lift speed (V_y)	100 m/min	90 m/min
Max. lift acceleration (a_y)	1.2 m/s ²	0.75 m/s ²
Type of extraction	Telescopic forks	Adaptable to box type



Twin-mast MLB stacker cranes for boxes

Designed to transport, handle, ship and store two or four unit loads in locations along a work aisle or at picking stations.

These stacker cranes can reach heights of more than 20 m, and carry up to four boxes of 50 kg each, with two twin-load extraction systems.

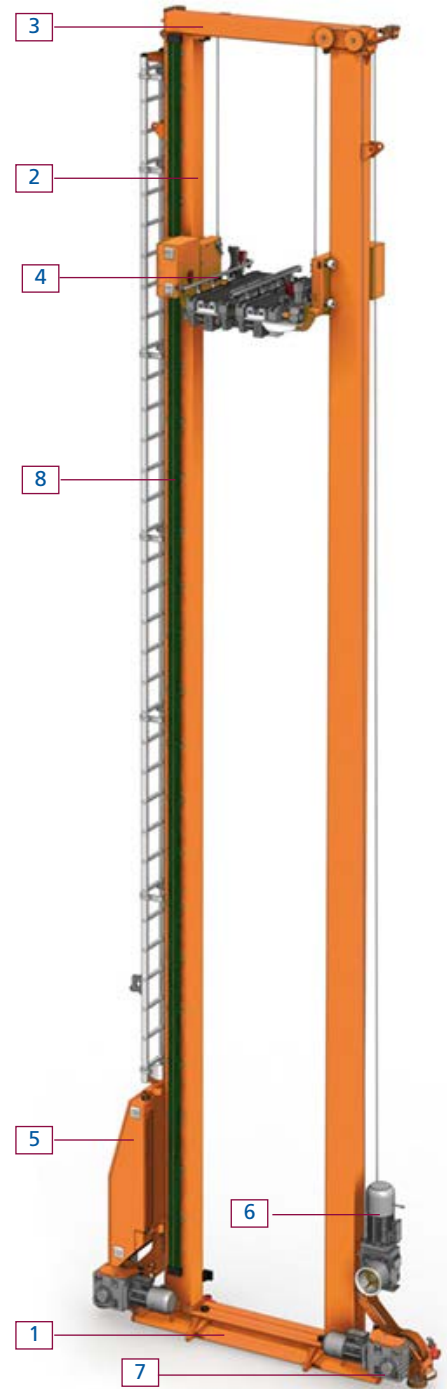

Core components

1. Lower guide base
2. Masts
1. Upper guide base
4. Lifting cradle
5. Electrical cabinet
6. Lift mechanism
7. Travel mechanism
8. Cable-free electrical conduction

Stacker cranes for boxes

TECHNICAL DATA: Twin-mast MLB stacker cranes for boxes			
Features	MLB100Q-2EPSF	MLB100Q-2EPDF	MLB100Q-2ECDF
Max. height	12,290 mm	12,290 mm	12,290 mm
Min. height	5,040 mm	5,040 mm	5,040 mm
Extraction systems			
Type of extraction	Single-deep twin telescopic forks	Double-deep twin telescopic forks	Double-deep twin telescopic forks with belts
Features			
Max. permitted load	2 x 50 kg / 2 x 100 kg	2 x 50 kg	2 x (50 + 50 kg)
Box/container size	600 x 400 mm / 800 x 600 mm		600 x 400 mm
Max. travel speed	250 m/min	250 m/min	250 m/min
Max. travel acceleration	1.45 m/s ²	1.45 m/s ²	1.8 m/s ²
Max. hoisting speed	90 m/min	90 m/min	90 m/min
Max. hoisting acceleration	1.5 m/s ²	1.5 m/s ²	1.5 m/s ²

The stacker crane's design helps minimise the forces transmitted to the structure that supports them. Thus, damage is prevented to the racks or the warehouse structure in the long run.

MECHANICAL COMPONENTS



Lower guide base

The lower guide base is made from a set of steel profiles and sheet metal welded together. It supports the weight which rests upon it (mast, cradle and load), and also moves the stacker crane along the aisle. This guide is covered by a plate on the top, where the mast is bolted into place.

The free and drive wheels are fitted at the ends of the guide with polyurethane stripping to improve the stacker crane's acceleration. The rear drive wheel is operated by a gear motor with a hollow axle fitted with a shrink ring, which is directly assembled on the wheel axle. The torque arm bears the turning moment.

On the opposite side is the hoisting mechanism, which consists of a gear motor with a solid axle in which the drum is fitted. The drum winds the hoisting cable and this in turn pulls the cradle up.



Close-up of the contrast wheels and drive unit

Horizontal contrast wheels are fitted at each end of the guide to ensure the guide base is correctly aligned with the bottom rail.

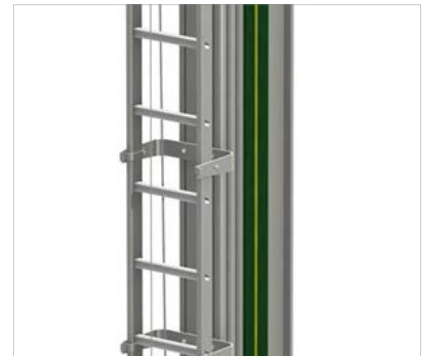

Masts

The mast models for 50 kg loads are made of an extruded aluminium profile, which incorporates the guides and grooves to fasten all the required components.

Models for 100 and 200 kg loads have a mast made from structural steel, in the form of a sheet-metal box that is reinforced inside. It has different precision-welded profiles to guide the hoisting of the cradle. The mast is machined to facilitate assembly of the different stacker crane elements.

In both cases, the masts are provided with threaded holes for securing the top and bottom guides bases.

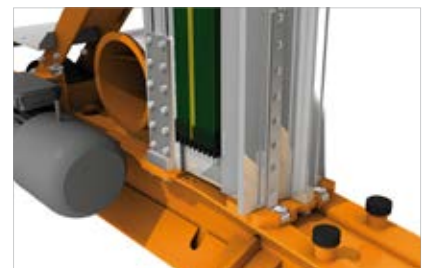

Close-up of the joint between the mast and the lower guide base



Upper guide base

The upper guide base joins the mast to the top rail by its contrast wheels, and enables travel movements to be performed without the risk of the miniload tipping over.

The upper guide base sits directly on top of the mast, where it is bolted into position.

Cradle or mobile hoisting frame

The miniload cradle is formed by two pieces – the guidance system and the extractor support –, which are bolted together. Both pieces are built with welded sheet metal and profiles, to which the rest of the components are fitted.

This part of the stacker crane must handle the unit loads by the extraction system, whose weight must be equal to or less than the load for which it was designed.

Hoisting operations

The aim of the hoisting mechanism is to raise the mobile frame vertically by means of a reinforced steel cable.

The mechanism comprises an AC motor designed to work with vector-controlled frequency inverters.

The cradle is raised and lowered by means of a cable which passes through a dual-pulley guide system located in the upper guide base and a winding drum in the lower guide base.





Extraction systems

It is possible to install several types of extraction systems according to the requirements of the loads stored in the miniload.

Mecalux classifies its extraction systems into two main groups:

- Extraction systems to handle a single box.
- Extraction systems that can handle two boxes at a time.
- Extraction systems that can handle four boxes at a time.

The table shows the most important data for each system.



Extraction system for a single box Extractor with telescopic forks

The telescopic fork is made of two blade structures, which slide together by means of heavy-duty guides and bearings. The fork is operated by gears and a drag chain for the upper blade. The couplings' high torsion resistance guarantees the uniform movement of the blade, avoiding excessive deflection with the load slipping to one end.

Two types of forks are available:

- **Single-depth telescopic forks (EPSF)**
Use this fork for horizontal handling, enabling unit loads to be deposited or extracted from single-deep racking.

■ Double-depth telescopic forks (EPDF)

Use this fork for horizontal handling, enabling unit loads to be deposited or extracted from double-deep racking. It can be used in both single and double-deep racking.

Motorised belt forks

This device comprises a telescopic fork fitted to a structure operated by a dual-belt system, which pushes the fork as it drags the load. It consists of two motorised mechanisms, which power each system of belts (telescopic operation; dragging operation). The operation is quick and fluid, and can be used to work on both sides of single-depth racking.

CHARACTERISTICS	EPSF	EPDF	ECDF	EGSF	EGDF*
Max. box size*	600 x 400 800 x 600	600 x 400	600 x 400	600 x 400	600 x 400
Max. box weight	100 kg	50 + 50 kg	50 + 50 kg	50 kg	50 kg
Max. fork speed with load	30 m/s	30 m/s	45 m/s	45 m/s	60 m/s
Max. fork speed unloaded	60 m/s	60 m/s	100 m/s	90 m/s	130 m/s
Max. acceleration with load	0.5 m/s ²	0.5 m/s ²	0.5 m/s ²	1 m/s ²	1 m/s ²
Max. acceleration unloaded	1 m/s ²	1 m/s ²	3 m/s ²	4 m/s ²	4 m/s ²
Aisle width	From 870 to 1,400 mm				

Sizes in mm * Consult our technical office.



Extraction system for 2 boxes

Combined fork extractor (ECDF)

Comprised of two extractors, this device makes the extraction process very flexible and allows two boxes to be deposited simultaneously. This type of extraction system has a telescopic fork fitted in the centre of a belt conveyor. The speed of the belts is synchronised with the exit and entry movements of the fork to allow the continuous input/output movements of the boxes.

As the belts are situated two millimetres above the height of the telescopic fork, they enable the boxes to switch sides or depths when running, without the need to move the fork. These belts also make it possible to swiftly deliver and collect

two boxes to work areas consecutively. This makes the system very flexible and speeds up processes.

Extraction system with lateral claws and folding rods (EGSF - EGDF)

This combined system enables up to two cardboard boxes to be handled simultaneously both in the racking and in the order prep areas. It consists of a system of vertical telescopic forks in which a series of folding rods are fitted.

When the rods are in a horizontal position, they grasp onto boxes (one or two units) to extract or push them. This movement takes place simultaneous to the turning of the rubber ribbons, which form the base of the extraction

system. The movements of these two independent ribbon conveyors are synchronised with the vertical forks. They facilitate the movement of the boxes onboard the machine to change their side or depth.

The big advantage of this system lies in its ability to manage cardboard boxes directly on the rack. As an alternative, the device can be fitted with a system to adapt to the different box sizes in intervals of ± 200 mm. This option makes the device very versatile in installations where cardboard boxes of different sizes are handled.

Type	Max. weight/load	No. of extractors	Extraction systems			
			EPSF	EPDF	ECDF	EG*
ML50	50 kg	1	X	X	-	-
ML100	50 kg	1	X	X	-	X*
	2 x 50 kg	1	-	-	X	-
	2 x 50 kg	2	X	X	-	-
	100 kg	1	X	X**	-	X*
MLB100Q	50 kg	1	-	-	-	X*
	4 x 50 kg	2	-	-	X	-
	2 x 100 kg	2	X	X	-	-

* Consult technical office ** Only for 600 x 400 mm boxes

PICKING SYSTEM CHART

Extraction system	Plastic box/container	Rigid tray	Cardboard box	Boxes per extractor
EPSF Single-deep telescopic fork	X	X	X	1
EPDF Double-deep telescopic fork	X	X	X	1
ECSF SD telescopic fork with combined belts	X	X	X	1
ECDF DD telescopic fork with combined belts	X	X	X	2
EGSF* Telescopic arms with side claws	X	X	-	1
EGDF* Telescopic arms with folding rods	-	-	X	2
EV** Extendable arms with suction cups	-	-	X	1

SD: single-deep. DD: double-deep ** Consult our technical office.



The power supply, safety measures and data, for both horizontal and vertical movements, are provided by cable-free and guide-chain free systems, thus avoiding costly, complex maintenance work.

ELECTRICAL COMPONENTS



Onboard electrical cabinet

The onboard electrical cabinet is fitted to the rear of the miniload stacker crane's mast. The controls are laid out so the stacker crane can be safely operated from the platform as a separate unit.

Power is supplied via an electrified guide rail fitted flush to the mast.

The electrical supply of the stacker crane can be turned off by a switch located inside the cabinet.



Safety controls

A power distribution cabinet in the aisles incorporates standardised power protection and electronic safety devices.

The access to each aisle is secure and controlled by a safety mechanism, as well as a button pad with warning lights and a restricted access key.



Data transmission

Communication is established between the decentralised periphery terminals and the fixed PC or PLC, along with the adjustable-speed drives, through infrared optical communication systems (photocells). These have ranges of up to 240 m and a transmission speed of 1.5 Mbps, for working temperatures of down to -30 °C, if necessary.

The fixed photocells are placed at the end of the aisle, and the onboard ones are mounted on the lower guide.

The data communication between the onboard cabinet and the cradle takes place by means of an infrared photocell equipped with a data transmission system.



The aisle equipment comprises a bottom rail, a top guide rail, positioning systems and aisle change systems.

AISLE EQUIPMENT

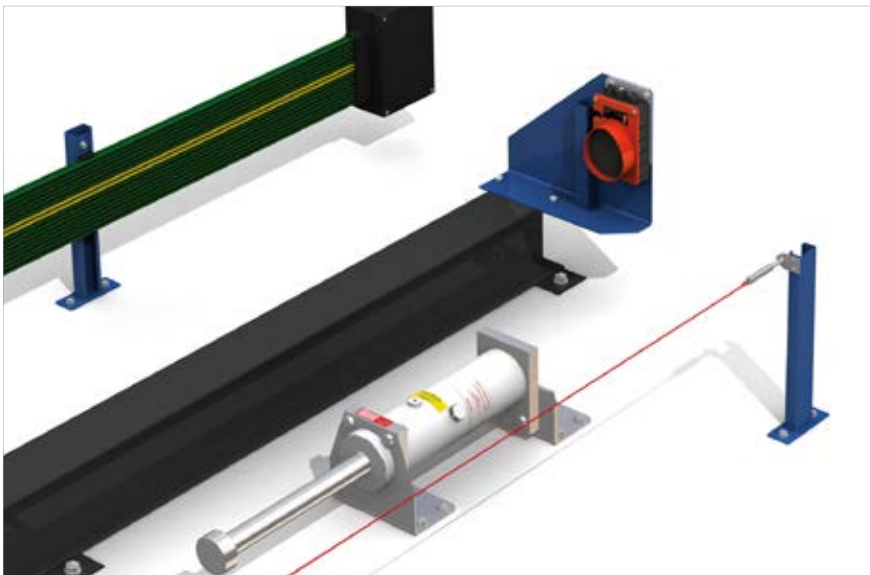

The bottom rail

An HEA-100 rail is fitted to the concrete slab by means of support plates and anchor bolts, at maximum intervals of 925 mm. At the ends, they are interspaced at intervals of approximately 600 mm.

To install the rail, holes are first drilled in the concrete slab, the threaded bolts are then inserted and the free space is filled with a special fixing resin.

Then, the support plates are fitted and adjusted to ensure they are level along the whole length of the aisle. The rails are also fitted by cutting the spliced points in a straight line, perpendicular to the axis of the aisle.

Finally, the joint of both rail sections are welded at the sides and in the centre, using special electrodes. The welding is polished down to a bead of no more than 4 mm.

The top rail

LPN 80 profiles can be used to make the top guide rail. This rail is fixed to the top profiles that join the rack structures by means of welded shim plates.

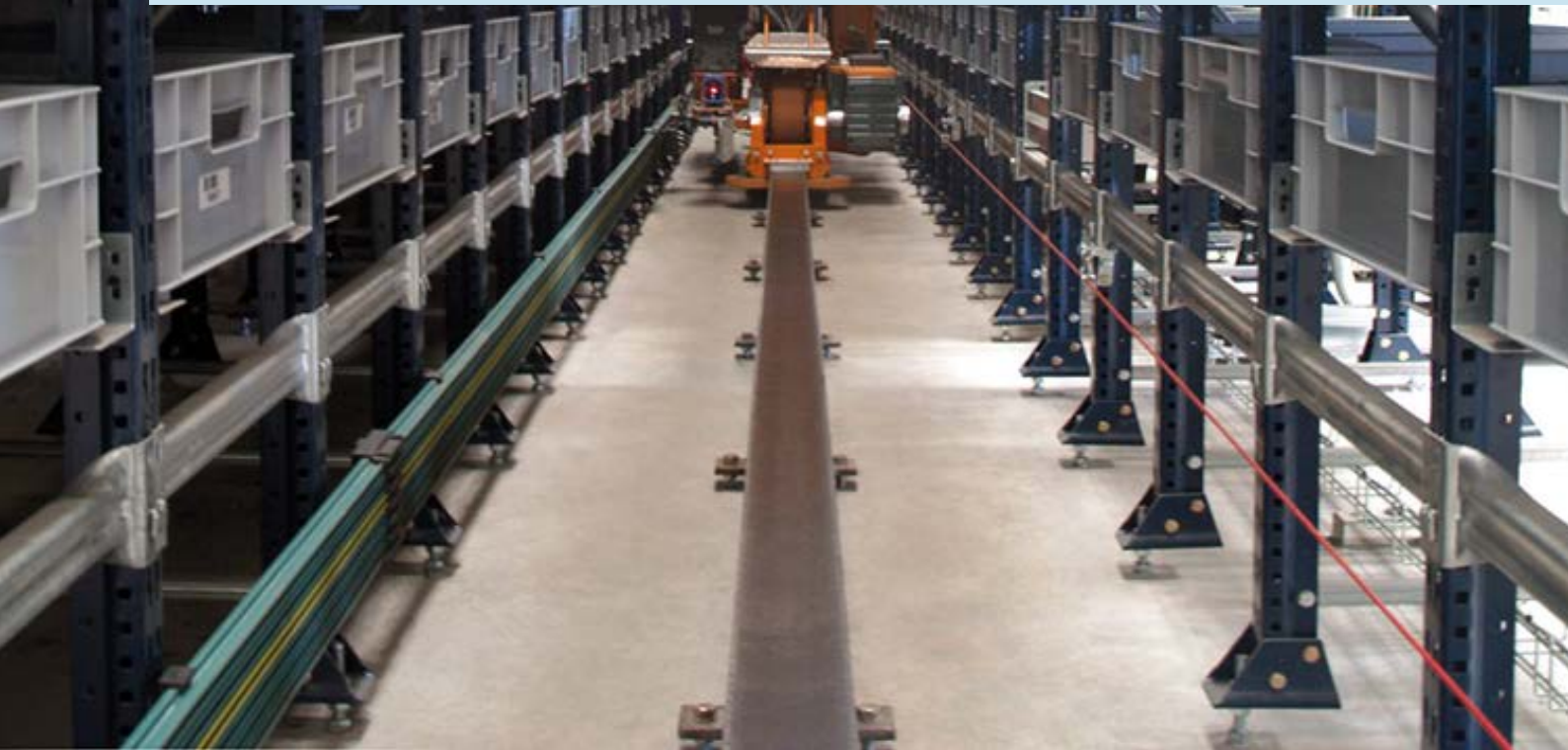

Positioning systems

The most reliable systems are used to measure the position of each axis accurately. The most suitable device is selected for each specific case.

- Laser rangefinders
- Absolute encoders



Precise positioning

A laser rangefinder reports the exact position along each axis (horizontal and vertical movement). This information is sent directly to the microprocessor in the servo-drive to properly control the stop position at any location.



Absolute encoders

Rotary devices with a codified value are neither repetitive nor incremental, producing an absolute and unique value for each angle of the shaft. They store the measured value, even when the machine has been disconnected.

Commonly installed on telescopic forks, they include anti-slip, anti-wear coupling devices and, in most cases, cover short distances.



Aisle change systems

When the rotation of stored goods is relatively low, but the storage volume is considerable, a stacker crane does not need to be installed in each aisle.

In this case, a system called a transfer bridge is used. This enables the miniload stacker crane to be moved from one aisle to another.

The stacker crane moves onto the bridge, where it is anchored and moved sideways to the destination aisle where the transfer is to take place.

This system allows the best possible performance of the miniload inside the aisle, although it is less flexible when changing aisles. Good management and optimised movements solve this problem, with sufficient forethought and planning. The installation of one system or another requires an exhaustive study of the factors involved in the operations which are performed in the installation.

The system can be easily expanded to include more stacker cranes, as necessary.

Mecalux's management system allows for suitable planning of movements and placement of goods, to ensure balanced workflows in the installation.





Mecalux's stacker cranes for boxes can operate in automated, semi-automated or manual modes, as necessary. The first mode corresponds to the normal operation of the installation, while the third mode is used for maintenance work.

MODES OF OPERATION

Automated mode

Here, orders are executed after being sent through a communication photocell from the conveyor management computer. In this mode, the following operations are carried out:

- Slotting,
- Extraction,
- Change of location,
- Correction of warehouse errors,
- Self-learning of the warehouse storage locations.

Semi-automated mode

Used for carrying out support functions, it includes:

- **Automated access to a location.**
The miniload is automatically positioned in the location ordered by the operator.
- **Automated fork cycle.**
A unit load is automatically deposited or extracted in the location indicated by the operator.

Manual mode

Enables restricted access to all the parts of the miniload stacker crane to carry out maintenance and repair work.



SAFETY EQUIPMENT



Mecalux has equipped its machines with basic ergonomic designs and their safety equipment needed to perform and maintenance operations as simply as possible.

Aisle end safety

Hydraulic buffers are securely fitted to the floor at the ends of the aisle. The buffers are calculated to absorb the full impact produced by the miniload stacker crane when travelling at a nominal speed.

Safety devices

- **Emergency circuit.**
- **Magnetothermic protection and thermal probe in motors.**
- **Current limiters** for the motors.
- **End stops** in hoisting, driving and **monitoring of speeds.**
- **Emergency stop areas** at aisle ends.
- **Travel and hoist movements** are only carried out when the fork and load are correctly centred.
- **Optical distance photocells** to confirm empty storage spaces.
- **Different devices allow safe access** to the aisles.
- **Velocity control.**

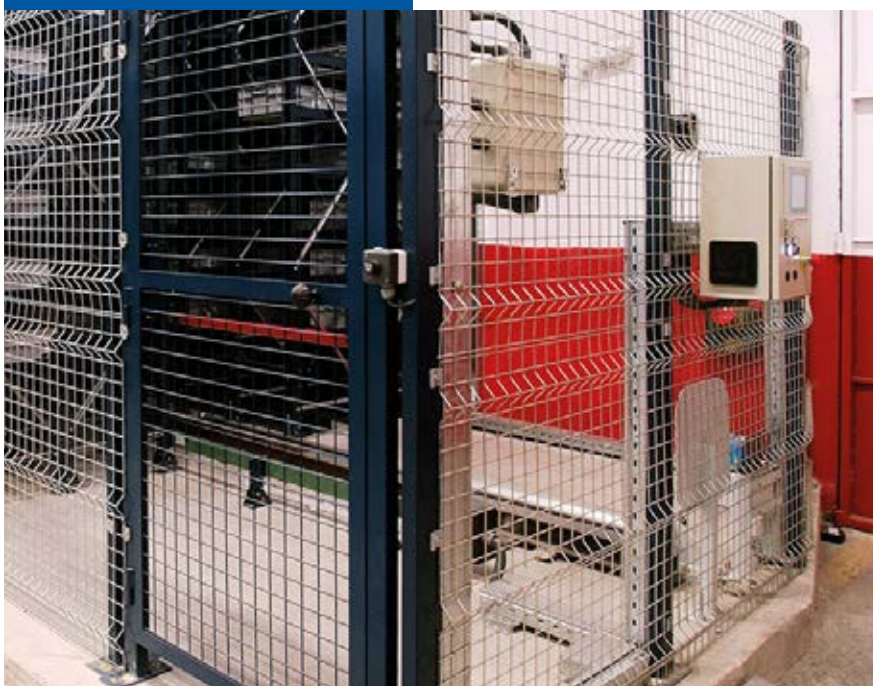



Box conveyor systems

Transporting light loads often goes hand-in-hand with demanding requirements (in terms of functionality and frequency), which can only be met with the seamless integration of each and every component of the system.

Mecalux offers a conveyor system which is scalable to the needs of its users and adjustable for growth.





CONTENTS

Types of conveyors	84	Technical features	96
Roller conveyors		Conveyor drive system	
Curved roller accumulation conveyors		Transmission system	
Continuous roller conveyors		Types of drives	
Free roller conveyors		Conveyor components	
Roller conveyors with delay lifting		Morphology of conveyor systems	
Mixed roller belt transfer		Transport unit	102
Hinged conveyors		Transport unit	
Booster conveyors		Working conditions	
Launcher roller conveyors			
Continuous belt conveyors			
Oblique box transfer			
Scales			
Transfer cars			
Lifts			
Picking stations			
Special handling systems			
Safety first			



A continuous conveyor system for boxes offers numerous benefits, including:

- **Reliability.** Components which comprise the conveyors have a proven track record and are highly reliable.
- **Low maintenance.** The compact design of all the conveyors enables maintenance work to be carried out easily.

- **Low operational cost.** The efficacy offered by these systems in work environments has a very positive effect on the ROI of the whole of the installation.
- **Scalability.** Components can be configured in many possible ways. Any of the components of the installation can be reused or expanded.
- **Durability.** the robust system is designed to withstand high-performance daily workflows.
- **Ergonomics.** The system features all ergonomic guidelines, facilitating interactions of the machine with the operator. It also simplifies the maintenance work in the installation.

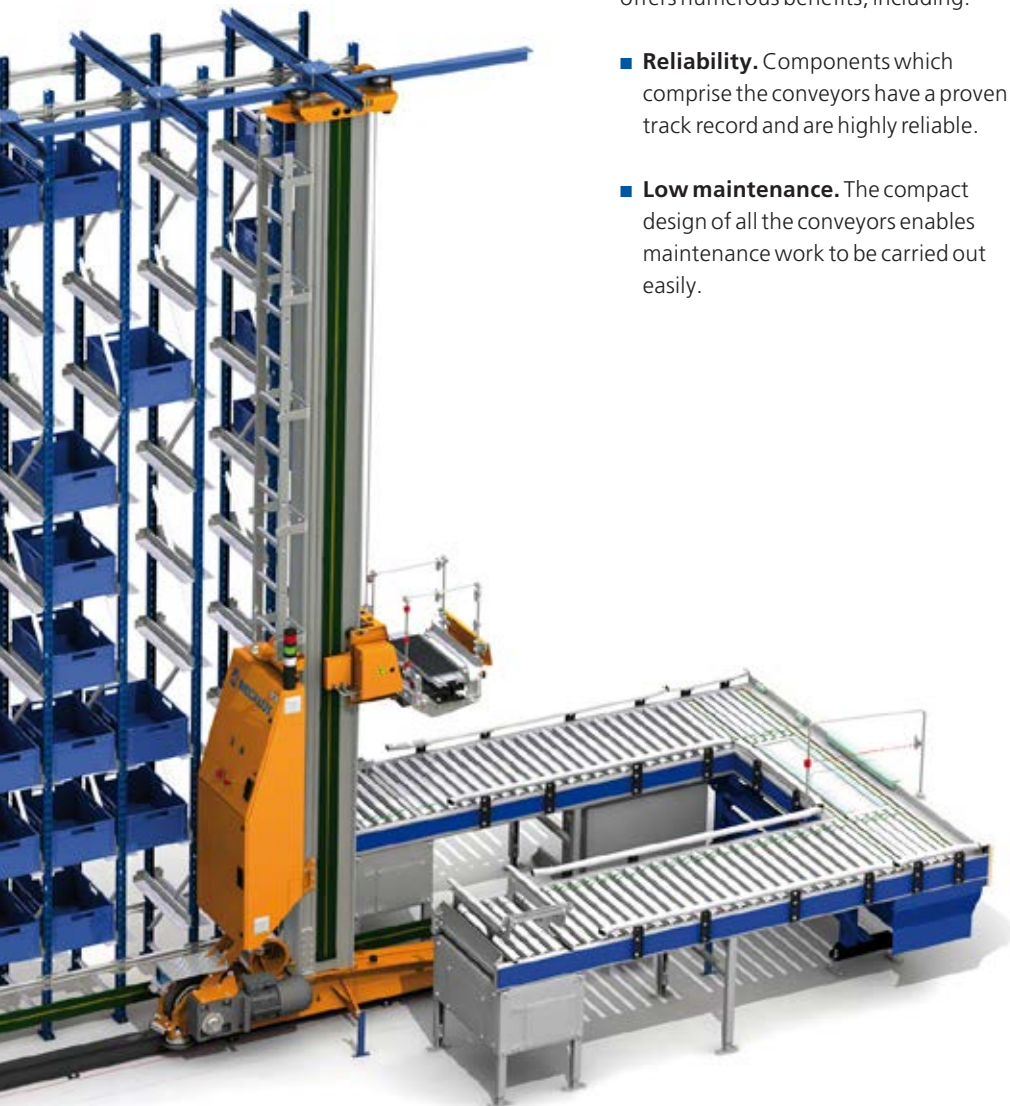

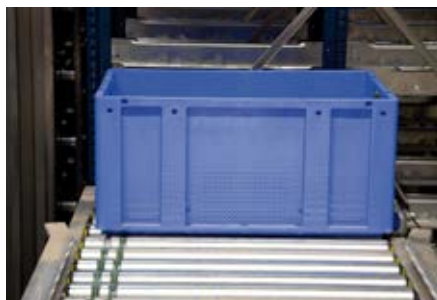
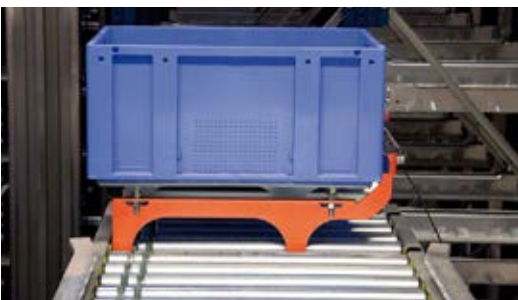

Transport units

The box transport systems developed by Mecalux can handle several types of units and transport bases. These can be either plastic or cardboard.

In addition, they can be adapted to different sized boxes according to the use.

- **Standard sized boxes (Euroboxes).**

Mecalux offers a wide range of plastic container types (see corresponding catalogue).

- **Cardboard boxes of different sizes** and all-purpose widths, which can adapt to a wide variety of weights and sizes. These units do not require any changes in the transport system.

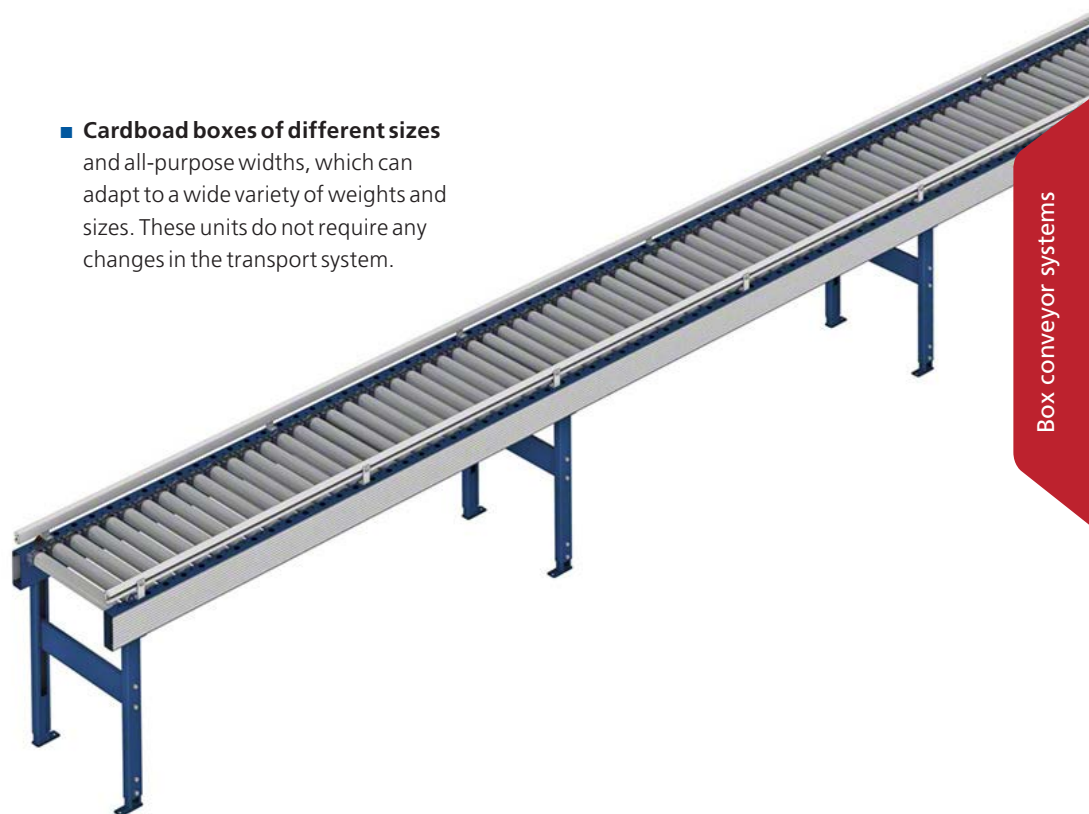

Box conveyor systems



The size of the load units and their transport base, together with their dimensions, are the chief factors used to determine the best conveyor system. Functionality, speed and incline are also factors which help to determine the optimal type of system for each application.

CONVEYOR SYSTEMS

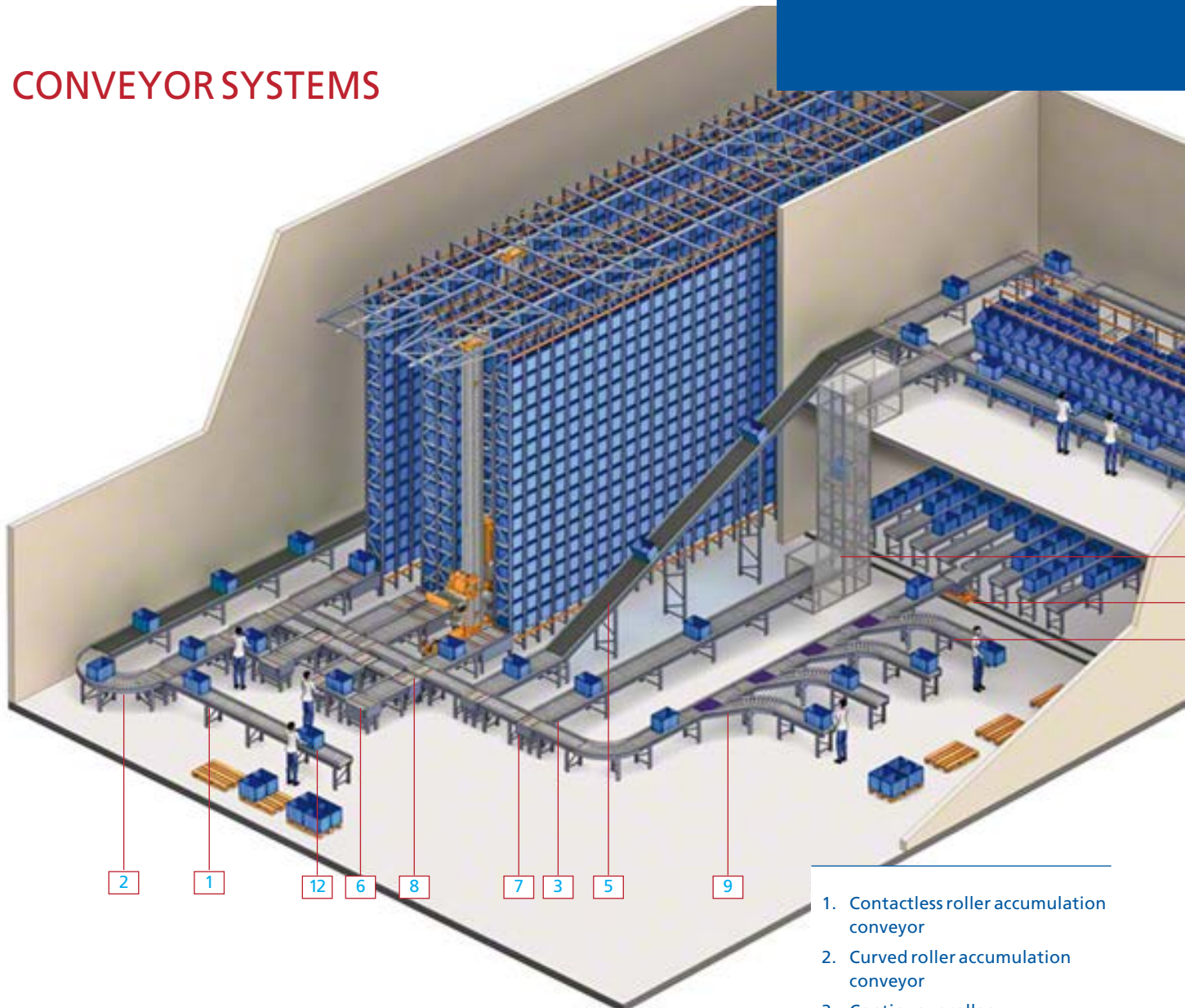

1. Contactless roller accumulation conveyor
2. Curved roller accumulation conveyor
3. Continuous roller conveyor
4. Free roller conveyor
5. Continuous belt conveyor
6. Roller conveyor with delay lifting

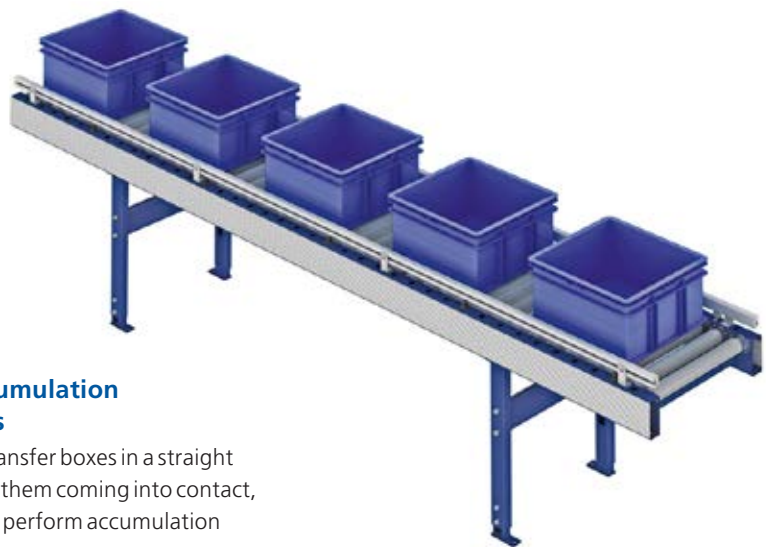

Roller accumulation conveyors

These can transfer boxes in a straight line without them coming into contact, and can also perform accumulation functions.

Their robust design guarantees their reliability in all work situations.

In all Mecalux conveyor models, the environmental conditions that are described in the technical data

tables refer to the standard model. However, they can be extended with the installation of suitable protective devices.

- 7. Double conveyor with delay lifting
- 8. Roller and belt transfer
- 9. Switch and exit/entrance conveyor
- 10. Conveyor transfer car
- 11. Lifts
- 12. Picking stations

TECHNICAL DATA: Roller accumulation conveyors

Transport units	Cardboard and plastic boxes and trays
Max. unit load weight	100 kg
Max. exterior width of conveyor	935 mm
Max. box width	600 mm
Min. conveyor length	450 mm
Max. conveyor length	3,000 mm
Min. box length (longitudinal direction)	150 mm
Max. box length (longitudinal direction)	800 mm
Standard transport height	570/750 mm
Variable transport height	350-3,000 mm
Standard speeds	25 / 45 / 60 m/min
Work conditions	Maximum humidity: 70% Ambient temperature: 0 °C to 40 °C



Curved roller accumulation conveyors

It is very useful to have these curved transport units when drawing non-straight flow lines or dealing with architectural or structural obstacles.

Boxes can be moved while making directional changes at various angles, with standard curve configurations of 30°, 45°, 60°, 90° and 180°. These conveyors can be combined with each other.

TECHNICAL DATA: Curved roller accumulation conveyors	
Transport units	Cardboard and plastic boxes and trays
Max. unit load weight	100 kg
Curve angle	30°/45°/60°/90°/180°
Accumulation zone 30°/45°/60°/90°/180°	0/1/1/2/4
Max. exterior width of conveyor	735 mm
Max. width for box	600 mm
Min. box length (longitudinal direction)	225 mm
Max. box length (longitudinal direction)	600 mm
Standard transport heights	570/750 mm
Variable transport height	350-3,000 mm
Standard speeds	25/45/60 m/min
Max. incline	0°
Work conditions	Maximum humidity: 70% Ambient temperature: 0 °C to 40 °C

Continuous roller conveyors

Use these to move boxes in a straight line when it is necessary to have a constant flow of goods, and the loads can accumulate by contact. It also is a system well suited to transporting loads over long distances or even on a slight incline.

The continuous roller transporter, as opposed to the accumulation conveyor, functions with a single motor that provides enough traction to maintain a continuous flow of loads that is optimal for covering long distances at a high flow rate.

TECHNICAL DATA: Continuous roller conveyors	
Transport units	Cardboard and plastic boxes and trays
Max. weight per linear metre	100 kg/m
Max. exterior conveyor width	735 mm
Max. width for box	600 mm
Min. conveyor length	2,250 mm
Max. conveyor length	30,000 mm
Min. box length (longitudinal direction)	150 mm
Max. box length (longitudinal direction)	800 mm
Standard transport heights	570/750 mm
Variable transport height	350-3,000 mm
Standard speeds	25/45/60 m/min
Max. incline	6°
Work conditions	Maximum humidity: 70% Ambient temperature: 0 °C to 40 °C



Free roller conveyors

This is a system of motorless rollers, suited to gravity flow sections, dispatch areas, or workstations.

TECHNICAL DATA: Free roller conveyors

Transport units	Cardboard and plastic boxes and trays
Max. unit load weight	100 kg
Max. exterior width of conveyor	935 mm
Max. width for box	800 mm
Min. conveyor length	450 mm
Max. conveyor length	3,000 mm
Min. box length (longitudinal direction)	150 mm
Max. box length (longitudinal direction)	800 mm
Standard transport heights	570/750 mm
Variable transport height	350-3,000 mm
Max. incline	From 4 to 8°
Work conditions	Maximum humidity: 70% Ambient temperature: 0 °C to 40 °C

Roller conveyors with delay lifting (LEE - LEC)

These are specially-designed conveyors for collecting and delivering loads to incoming and outgoing stations of stacker crane run automated warehouses.

These conveyors come in two main types: single-load and twin-load. They work perfectly with the extraction systems of standard Mecalux stacker cranes.

This system combines a roller conveyor and a hoisting assembly that gives the stacker crane's extractor access the load from underneath.



TECHNICAL DATA: Roller conveyors with delay lifting

	Conveyor LEE	Conveyor LEC
Transport units	Cardboard and plastic boxes and trays	Cardboard and plastic boxes and trays
Max. unit load weight	100 kg	2 x 50 kg
Max. exterior width of conveyor	935 mm	1,352 mm
Max. width for box	800 mm	600 mm
Max. conveyor length	935 mm	502 mm
Max. load length	600 mm	400 mm
Standard transport height	750 mm	750 mm
Variable transport height	500-3,000 mm	590-3,000 mm
Speed	25 m/min	25 m/min
Working conditions	Maximum humidity: 70% Ambient temperature: 0 °C to 40 °C	Maximum humidity: 70% Ambient temperature: 0 °C to 40 °C



Mixed roller belt transfers

This unit offers high-performance solutions to intersection problems and adapts to the most complex facility design.

This system can change directions by 90° and combines a fixed roller conveyor and lifting belt conveyor arranged perpendicular to each other. In addition, it incorporates a hinged buffer to ensure

the boxes being transferred stay perfectly in line.

According to the distance the belt conveyor must cover in one direction, use either a symmetrical system (greater transport distance required) or an asymmetrical one (shorter distance required).

TECHNICAL DATA: Mixed roller / belt transfer

Transport units	Cardboard and plastic boxes and trays
Max. unit load weight	100 kg
Max. exterior conveyor width	736 mm
Max. width of box on rollers	600 mm
Max. conveyor length	838 mm
Min. box length (longitudinal direction)	300 mm
Max. box length (longitudinal direction)	800 mm
Standard conveyor heights	570/750 mm
Variable transport height	400-3,000 mm
Standard speeds	25/45/60 m/min
Max. incline	0°
Work conditions	Maximum humidity: 70% Ambient temperature: 0 °C to 40 °C



Single hinged conveyor

Hinged conveyors

This item can be incorporated into accumulation or free roller conveyor systems. It is designed to let operators or forklifts pass through the conveyor on that level.

A single hinged conveyor is installed when only people need to get through. Double hinged conveyors are used where forklifts are involved.

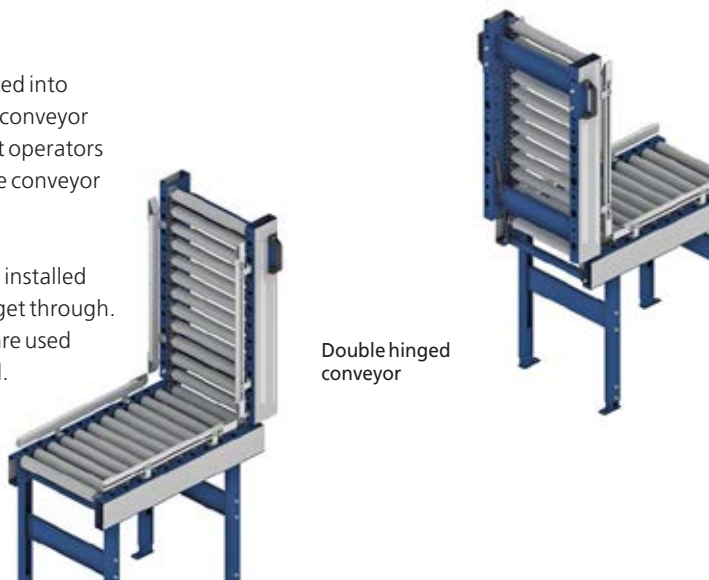

Double hinged conveyor



Booster conveyors

This conveyor is designed to change the direction in which the load is travelling at a given moment, easing the passage of goods and optimising cycle times.

TECHNICAL DATA: Booster conveyors

Transport units	Cardboard and plastic boxes and trays
Max. unit load weight	50 kg
Max. exterior width of conveyor	735 mm
Max. width for box	600 mm
Min. conveyor length	675 mm
Max. conveyor length	1,050 mm
Min. box length (longitudinal direction)	225 mm
Max. box length (longitudinal direction)	600 mm
Standard conveyor heights	570/750 mm
Variable transport height	350-3,000 mm
Standard speeds	25/45/60 m/min
Max. incline	0°
Work conditions	Maximum humidity: 70% Ambient temperature: 0 °C to 40 °C



Launcher roller conveyors

Use this system to make a 90° change in direction in which the load is pushed perpendicularly at a junction, aided by a motorised roller.

One of its advantages is the quick return on investment without having to sacrifice orderly, profitable operations.

This component provides great flexibility for receipt and dispatch functions.

TECHNICAL DATA: Launcher roller conveyors

Transport units	Cardboard and plastic boxes and trays
Max. unit load weight	50 kg
Max. exterior conveyor width	735 mm
Max. width for box	600 mm
Max. conveyor length	900 mm
Box length	400 mm
Standard conveyor heights	570/750 mm
Variable transport height	350-3,000 mm
Standard conveyor speeds	25/45/60 m/min
Max. incline	0°
Work conditions	Maximum humidity: 70% Ambient temperature: 0 °C to 40 °C



Continuous belt conveyors

Use this unit to move boxes in a straight line when a uniform flow of unit loads is required, maintaining a constant distance or position between them.

It is also suitable when transport at speeds of more than 60 m/min is required or when the surface contact between loads and rollers is insufficient.

TECHNICAL DATA: Continuous belt conveyors

Transport units	Cardboard and plastic boxes and trays
Max. exterior width of conveyor	735 mm
Max. width for box	600 mm
Min. conveyor length	675 mm
Max. conveyor length	30,000 mm
Min. box length (longitudinal direction)	225 mm
Max. box length (longitudinal direction)	800 mm
Standard conveyor heights	570/750 mm
Variable transport height	350-3,000 mm
Speeds	25/45/60 m/min
Max. incline	4°
Work conditions	Maximum humidity: 70% Ambient temperature: 0 °C to 40 °C



Oblique box transfer



Induction box transfer

Oblique box transfers

Branches should be included onto secondary routes or induction lanes onto high-speed lines in installations where a large quantity of transport units are moved around the system. The units from this group of products are the most useful for facilitating high-speed directional changes.

TECHNICAL DATA: Oblique box transfers

Transport units	Cardboard and plastic boxes and trays
Use	Oblique transfer
Max. unit load weight	50 kg
Min - max conveyor length	1,650-1,935 mm
Max. exterior width of conveyor	735 mm
Standard conveyor heights	570/750 mm
Non-standard conveyor heights (min. - max.)	350 - 3,000 mm
Standard speeds	25 / 45 / 60 m/min
Work conditions	Maximum humidity: 70% Ambient temperature: 0 °C to 40 °C

TECHNICAL DATA: Induction box transfers

Transport units	Cardboard and plastic boxes and trays
Use	Induction transfer
Max. unit load weight	30-50 kg
Max. conveyor length	1,935 mm
Max. exterior width of conveyor	735 mm
Standard conveyor heights	570/750 mm
Non-standard conveyor height (min. - max.)	450-3,000 mm
Standard speeds	25 / 45 / 60 m/min
Work conditions	Maximum humidity: 70% Ambient temperature: 0 °C to 40 °C

Scales

The main function of this conveyor is to ensure the load meets set installation working conditions. As such, it is used to monitor the maximum weight of the load before it is placed in storage, or to prevent excessive weight per box type or for operator handling.



TECHNICAL DATA: Scales

Transport units	Cardboard and plastic boxes and trays
Max. unit load weight	100 kg
Min. conveyor length	750 mm
Max. conveyor length	1,050 mm
Min. box length (longitudinal direction)	150 mm
Max. box length (longitudinal direction)	800 mm
Max. exterior width of conveyor	735 mm
Max. width for box	600 mm
Standard conveyor heights	570/750 mm
Variable transport height	350-3,000 mm
Standard speeds	25 / 45 / 60 m/min
Work conditions	Maximum humidity: 70% Ambient temperature: 0 °C to 40 °C

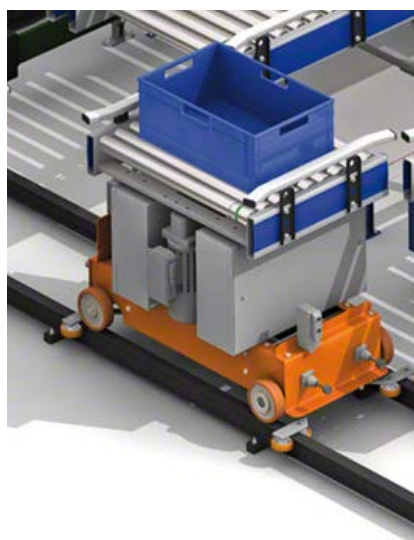
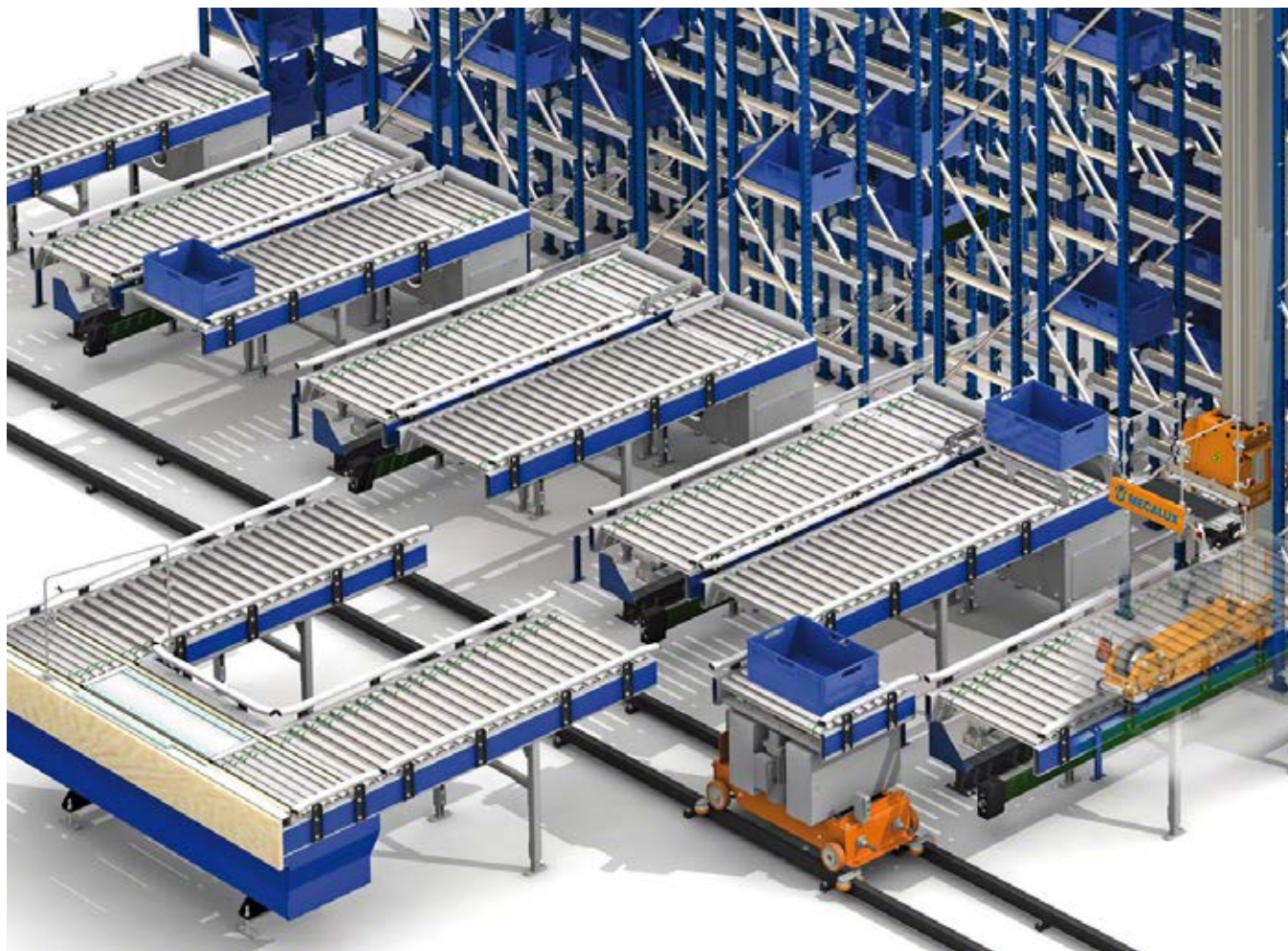

Transfer cars

This non-continuous system for delivering handled units to different receiving stations can be an important part of an operational environment that needs a variety of resources and where high functionality is not an essential requirement. Another benefit is the quick return on investment without having to forego orderly and profitable operations.

These devices provide a great deal of flexibility in receipt and dispatch operations.

TECHNICAL DATA: Transfer cars

Transport units	Cardboard and plastic boxes and trays
Use	Horizontal transfer
Max. unit load weight	50 kg
Max. load width	600 mm
Max. load length	400 mm
Max. load height*	420 mm
Standard speed	60 m/min
Work conditions	Maximum humidity: 70% Ambient temperature: 0 °C to 40 °C

* For Mecalux boxes

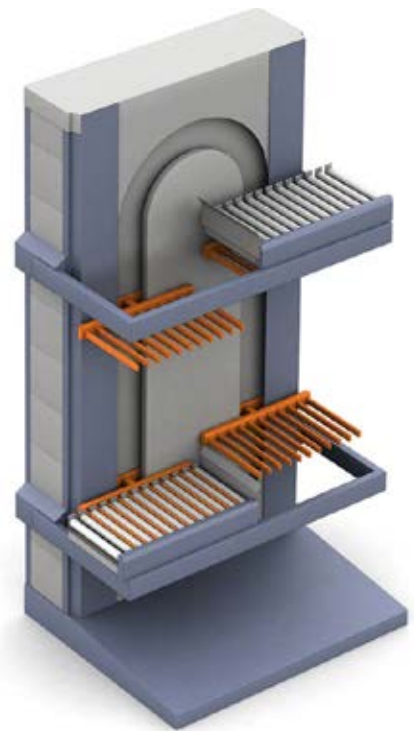

Lifts

Lifts provide a design solution in cases when the floors or transit areas are limited, but these areas still must be profitable. As such, a range of lifts is available, capable of distributing the units to different levels both continuously or not, without affecting operations in the installation.

These devices enable the loads to be moved to different levels of the installation.

Non-continuous lifts

These lifts or lower boxes vertically in circuits with medium flows, connecting different floors and circulation levels.

Continuous lifts

These vertical lifts allow continuous lifting and lowering of goods in situations that require high flow rates.

It is characterised by its large capacity and ability to move loads at high speeds, thanks to its continuous lifting operations.





Picking stations

Operators interact with the automated system at these stations. Goods stored in the warehouse are managed and handled from these points, and also verified within the circuit of conveyors.

Their ergonomic design guarantees quality load handling and a safe working environment.

Safety is ensured by the different equipment in the stations, minimising health and safety hazards for the operator who is working at the picking station.

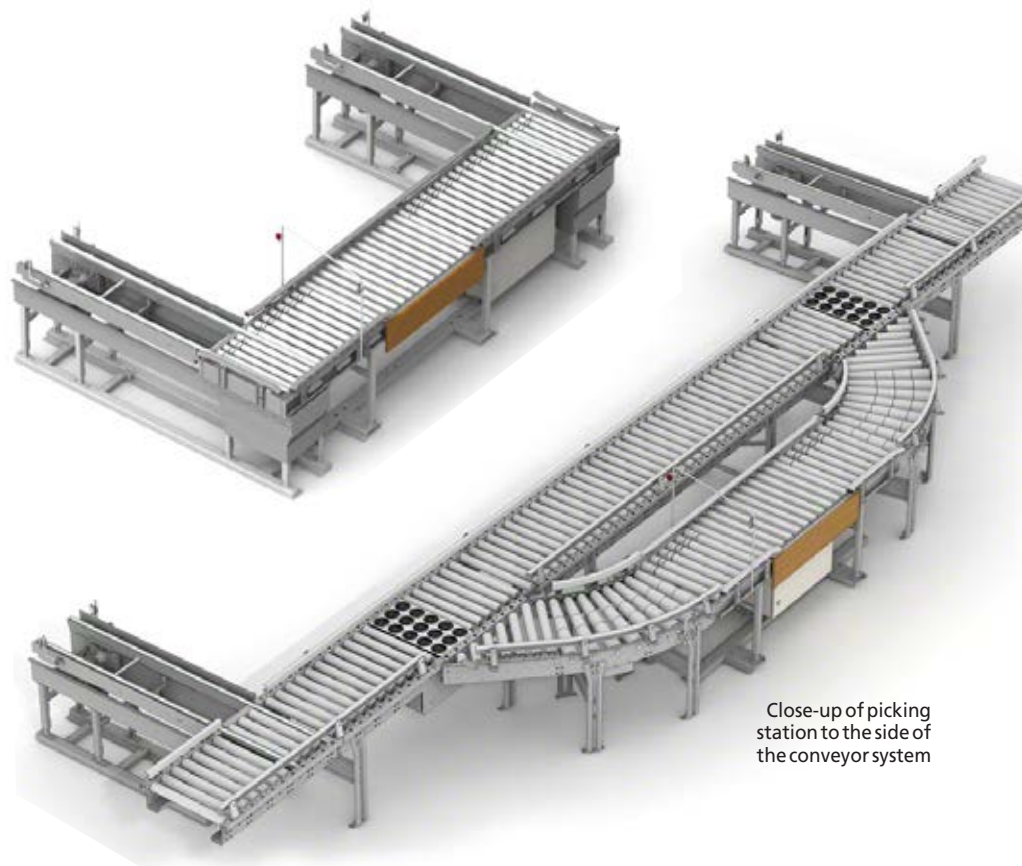

Close-up of picking station to the side of the conveyor system

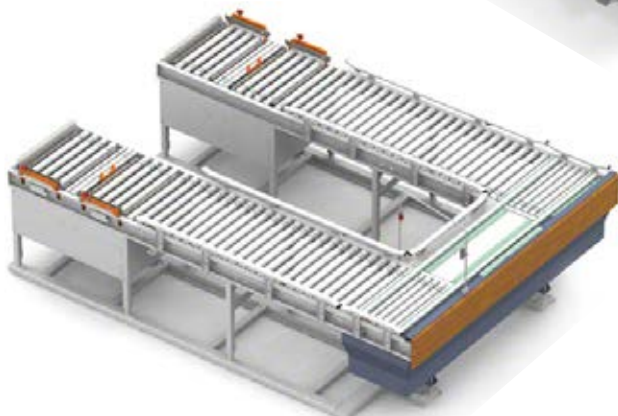

Close-up of a picking station at the front of a system with a single workstation and double extraction forks



Special handling systems

Mecalux offers a range of products for special storage situations and projects with major operational capacities.

These devices include:

- Box sorters
- Stackers
- Vertical lift modules
- Carousels
- Plastic box folders

Mecalux integrates these products into complex logistics systems for boxes, according to the requirements of each installation.

Safety first

Safety devices, similar to those required in pallet rack installations, may need installing depending on the results of risk analysis.

Metal mesh partitioning should be installed where required, to prevent operators from coming into contact hazardous, moving parts. The control system stops the movement of the machines when the access doors open.

The following images show different solutions and adaptations, depending on each installation's specific requirements.



Designed and developed by Mecalux, the systems for moving light loads are particularly suitable for responding to market demands, offering a quality, low-maintenance product. They are built with standard electrical and mechanical components, which guarantee the reliability and supply of spare parts.



TECHNICAL FEATURES

Conveyor drive systems

Speeds

Depending on the characteristics of the unit being transported, different speeds are studied for the drive movement. The speed is directly related to the operational capacity of the origin and destination points.

Operational power

The factors which determine the operational power of a conveyor system's components are the weight of the units being transported, along with the different features included in the installation. Mecalux offers a wide range of drive mechanism options, which provide solutions to all the tasks needed for proper in-warehouse operations.

Drive rollers

The roller has a motor fitted internally and is mechanically connected by means of elastomeric belts to a group of rollers that rotate in sync with the motorised roller.

Transmission systems

The operation devices are chosen according to the nature of the unit load and the operation method of the conveyor system. The systems can be:

- Drive rollers
- Drive belts
- Toothed belts
- Conveyor belts
- Drive shafts and chains

Drive rollers

The drive rollers are top quality and can work at a great number of speed and with different loads.



Drive rollers



Drive belts

Roller movements are driven by a system of drive belts, built into one side of the conveyor's chassis.



Toothed belts

Highly-resistant long-lasting toothed belts are implemented on mixed transfers with crosswise movements or rollers for boxes. These are made from highly adherent materials on the surface that comes in contact with the load, while the interior surface is very flexible.

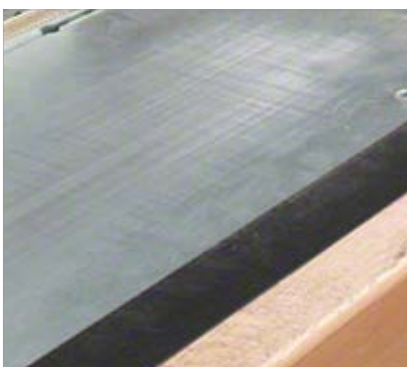

Conveyor belts

Unit loads move as the elastomeric belt turns. The boxes are carried along the frictionless conveyor belt system.



Drive units

The turning movement of the belts is run by the motor and the axle-pulley system, which joins to the rest of the conveyor's rollers.

Types of drives

A number of different types of drive are commonly used in light conveyor systems. Asynchronous engines are a good option for standard systems and have a proven track record.

The environmental and working conditions also determine the selection of the most suitable form of drive.

Mecalux's continuous conveyor systems are designed by selecting the most suitable components for each situation. This main design priority is used to achieve the desired quality level.

Conveyor components

Depending on the nature of the box to be transported and the role of the functional unit, different conveyor components can be used for the same conveyor system.

The most common components include:

Roller with metal casing

As a standard conveyor component, the metal casing of the roller cylinder gives it the adhesion needed to move handled units in most situations.



Roller with metal casing

Roller coated in anti-slip material

This system is used when adhesion between the unit load and the roller is required to prevent the unit load from slipping.



Poly-V Belts (polyvinyl)

Polyvinyl belts are an alternative to O-ring belts when loads of more than 50 kg need to be transported, as this type offers better traction than rollers.



Elastomeric belts

A universal system used to transport units with uneven bases or which are incompatible with any other conveyor system.

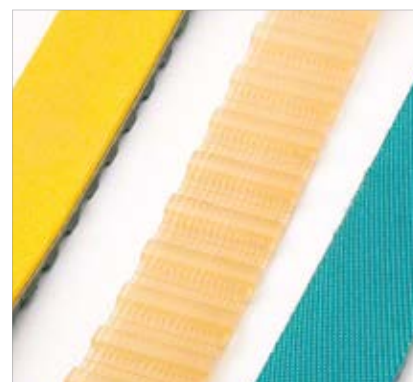

High-adhesion elastomeric belt

When the transport unit is used to climb slopes or at high speeds and the transportability must be guaranteed, the system uses a belt made from a rough or more adherent material.

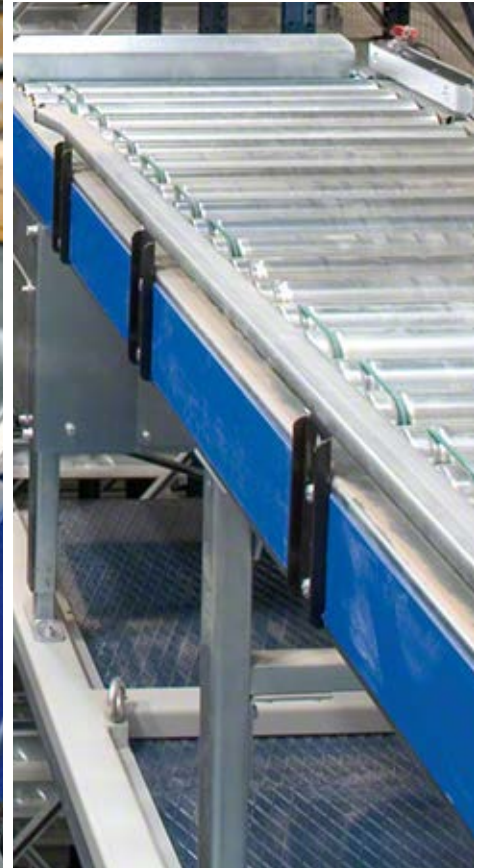

Different heights can be built, as needed.

Morphology of conveyor systems

Conveyor levelness

The levelness of the conveyor refers to the incline along which the load is transported.

Height

All conveyors have their own support structure, which allows them to be height-adjustable and ergonomic to facilitate operator tasks, as well as make it possible to adjust transport levels between floors.

Length

This refers to the maximum distance that can be covered with a single conveyor using the same drive mechanism.

Width

The width is directly related to the size of the transport unit.

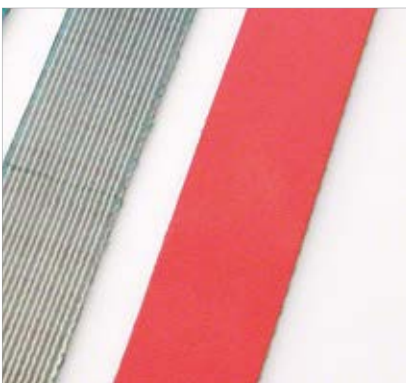

Elastomeric belt for easy sliding

When making changes in direction with certain types of elements, the handled unit must slide on its base. So, the system requires a surface which facilitates this task. The solution is a belt made from a highly-resistant material, which permits easy sliding.



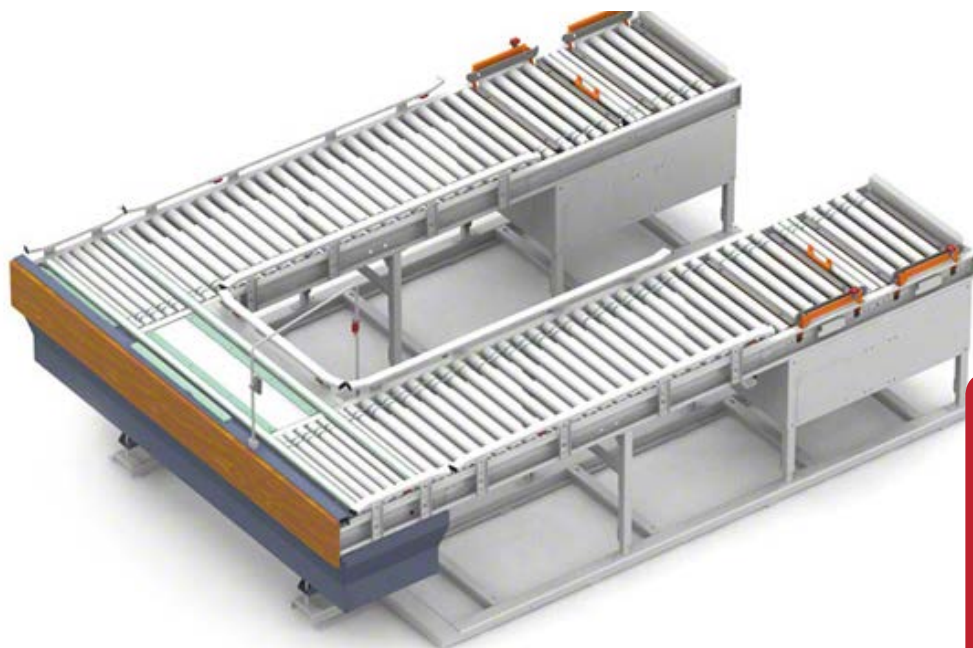

Distances within an installation can be covered by means of different devices included within the group of products discussed here.

Mecalux offers a standard conveyor solution, which covers all the situations likely to occur in a typical work environment.

The use of drive mechanisms and presence-detection systems by means of mechanical or optical detection devices enables the boxes to be moved under controlled conditions to the desired positions.

All the parts which make up these conveyors are seamlessly integrated with the rest of elements of the installation use to light loads within the warehouse. In many cases, they are also built with intelligent systems fitted inside them.

In automated conveyor systems, the container or transport unit plays a vital role in guaranteeing the proper functioning and performance of the installation.



TRANSPORT UNIT

Plastic containers (boxes) are often used as transport units. Metal containers are also used to a lesser extent. In certain circumstances, the goods are transported in trays (metal or plastic), which replace the standard container. If the goods are packaged, either definitively or temporarily, in a sufficiently strong cardboard box, this can be used as the transport unit.

The transport unit must fulfil a series of characteristics, which permits it to be handled in automated working environments. Among these characteristics, the following should be noted:

- The contact surface must be flat and stable with sufficient thickness to guarantee no more than 6 mm of deformation due to deflection.
- The area for the barcode has to be at least 80 mm above the base of the transport unit.
- The function of the photocells must be guaranteed. The light beam must not pass through the box. The use of transparent containers or containers made of thin mesh can cause detection problems.
- If stacked units are being transported, they must keep the same shape and form when accelerating, decelerating and changing direction.

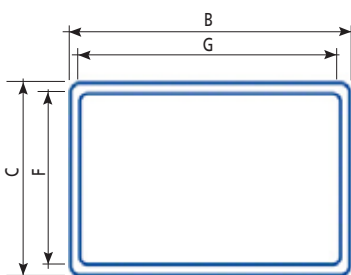

Smooth bottom

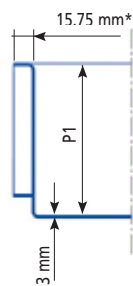

Reinforced

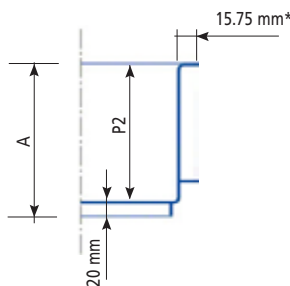

* Along the whole perimeter.





- If possible, units should not have holes in the base nor in the first 50 mm of the sides to minimise damage to the belts from leakage.
- The plastic deformation of the base in the rack must be no more than 5 mm and the elastic deformation no more than 10 mm.
- External maximum tolerance +/- 2 mm.
- Ideally, foldable boxes should have single hinges, as they are sturdier and more stable.

The general table for each system indicates the sizes and weight of the unit load transported.

Mecalux has developed its own range of plastic boxes to improve the reliability of the box conveyor systems and reduce problems with certain container types. Boxes have been designed in accordance with Eurobox regulations and comply with the mechanical requirements for intensive use in Mecalux's conveyor and storage systems. Available models are shown in the table below.

Working conditions

Temperature

Standard material handling systems can be operated in a range of temperatures. Mecalux conveyor components are designed to work between -30 °C and +40 °C.

Humidity

The relative humidity in the working environment can create a need for additional mechanical and electrical protection systems in the installation. For instance, moving transport units may require lower handling speeds, in addition to other specially protected devices.

TECHNICAL DATA: Mecalux Euro boxes

Model	Height	Width	Length	G	F	P1	P2	
CME	640 x 420	420	600	400	568.5	368.5	417	-
	640 x 320	320	600	400	568.5	368.5	317	-
	640 x 240	240	600	400	568.5	368.5	237	-
	640 x 170	170	600	400	568.5	368.5	167	-
	640 x 120	120	600	400	568.5	368.5	117	-
CME reinforced	640 x 420	420	600	400	568.5	368.5	-	400
	640 x 320	320	600	400	568.5	368.5	-	300
	640 x 240	240	600	400	568.5	368.5	-	220
	640 x 170	170	600	400	568.5	368.5	-	150
	640 x 120	120	600	400	568.5	368.5	-	100

Dimensions in mm



Computer Systems for Management and Control

The primary objective of this computer system is to control, coordinate and manage all the processes carried out in the warehouse, from the information received from the customer's ERP to controlling each movement done by the mechanical and electrical devices. The system, in effect, is the brain upon which decisions and reactions depend.





CONTENTS

Control software (Galileo)	108
Functions	
Architecture	
Communications	
EASY WMS warehouse management system	110
Functions of Easy WMS	
Functionalities	
■ Receipts	
■ Storage	
■ Control	
■ Dispatches	
■ Automated transport system	
■ Tools	
PTL and radiofrequency devices	116
Pick-to-light / Put-to-light	
■ Architecture	
■ Pick-to-light operations	
■ Put-to-light operations	
Radiofrequency devices	
Module for integrating external systems	



Mecalux, aware of the demanding requirements of the computer applications run in its installations, has set up a Software Development Centre staffed by a team of top-notch professionals who have in-depth knowledge and a broad experience with the best platforms for developing code and programming.

All the development work carried out about information systems for automated solutions meets the following requirements:

- Software development following the latest technological standards, using powerful and internationally recognised databases and programming languages.
- **Scalable systems** enable an installation's functions and number of users to be increased without having to alter previous configurations.
- **Centralised configuration systems** make it possible to change and/or replace hardware elements without risking data and information.
- **Safe communication systems** through the use of encoded transmission data, passwords, audits, etc.
- **Hot database backups** allow the machines to continue working without reducing the security of information.
- **Applications designed to be easily updatable** throughout the life of the product, thanks to a system of compatible versions.
- **Online accessibility** enables remote connections to receive help from a Mecalux support team when situations require guidance from technical experts.

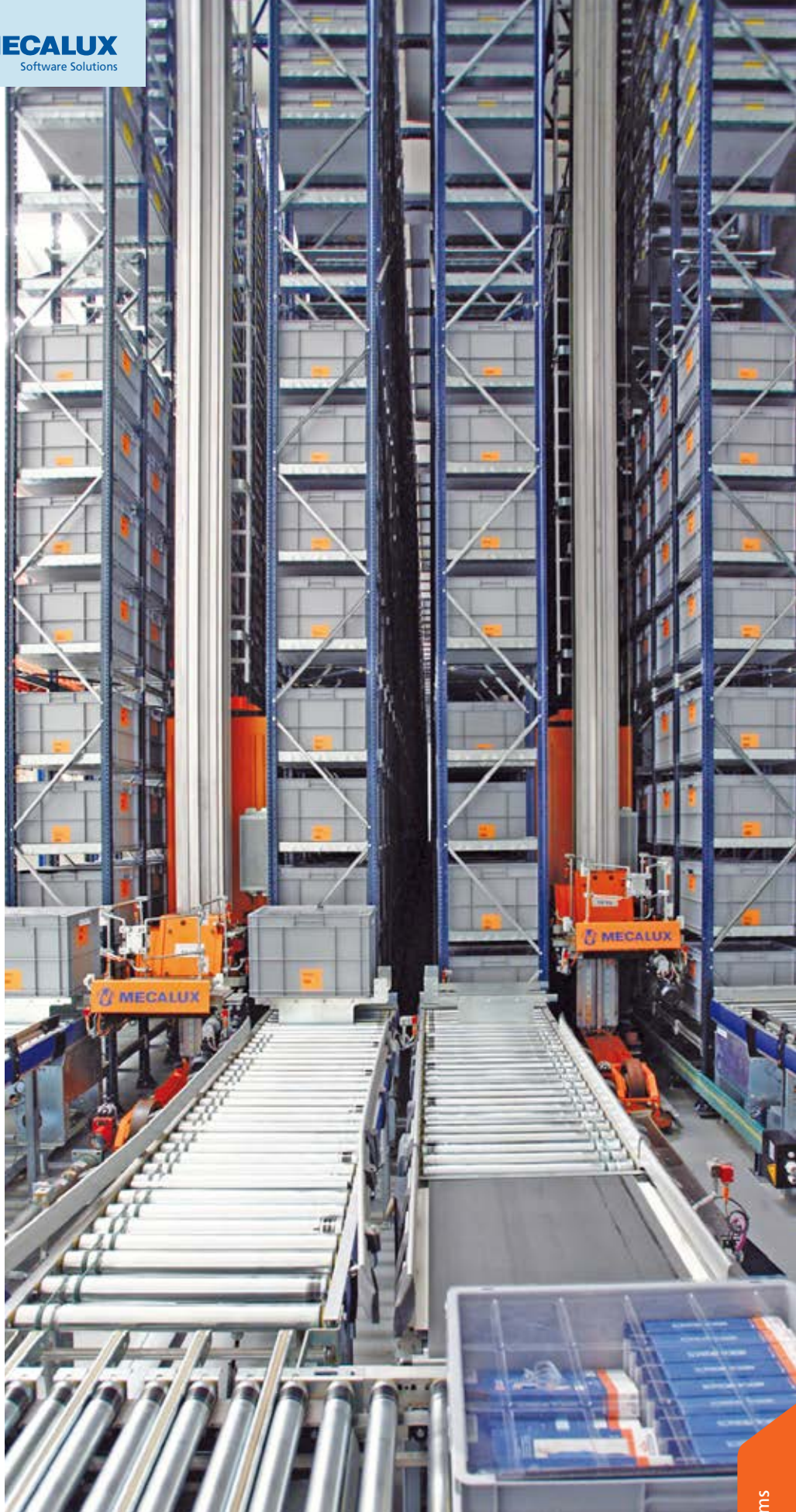

Mecalux has a support service department, which deals with teleservice and remote maintenance work to provide high-quality service and proper supervision of the different installations. A team of professionals is available 7 days a week, 24 hours a day, 365 days a year, to carefully assist the operations in each warehouse and achieve maximum performance levels.

Through investments made to develop information technologies, Mecalux can offer a package of easy deployment software solutions, which ensure the system functions smoothly from outset.

This package of software solutions for logistics installations includes two essential applications:

- **Control software:** for controlling machinery.
- **Management software:** for running operations in installations.



To simplify parameter configuration and start-up processes of the installations, Mecalux has developed a control software solution for programming totally standard computer bots based on internationally recognised technological platforms.

CONTROL SOFTWARE (GALILEO)

Functions

The basic function of the Galileo control software package designed by Mecalux is to manage the electromechanical devices in the installations which transport and store goods, following the instructions received from the warehouse's management software.

The control software performs the

following tasks to carry out these functions:

- **Displaying and auditing** the status of the different components in the installation, as well as managing breakdowns and alarms.
- **Controlling the different electromechanical elements** in the installation, applying the optimal control algorithms in each case.
- **Coordination and communication** between the different control sub-systems and the top level of management (WMS).

Architecture

The control system has been developed as per the latest standards in hardware and software.

The application is divided into three levels:

- **User service layer.** This level includes the application which deals with the user interface and is connected to the warehouse services layer.

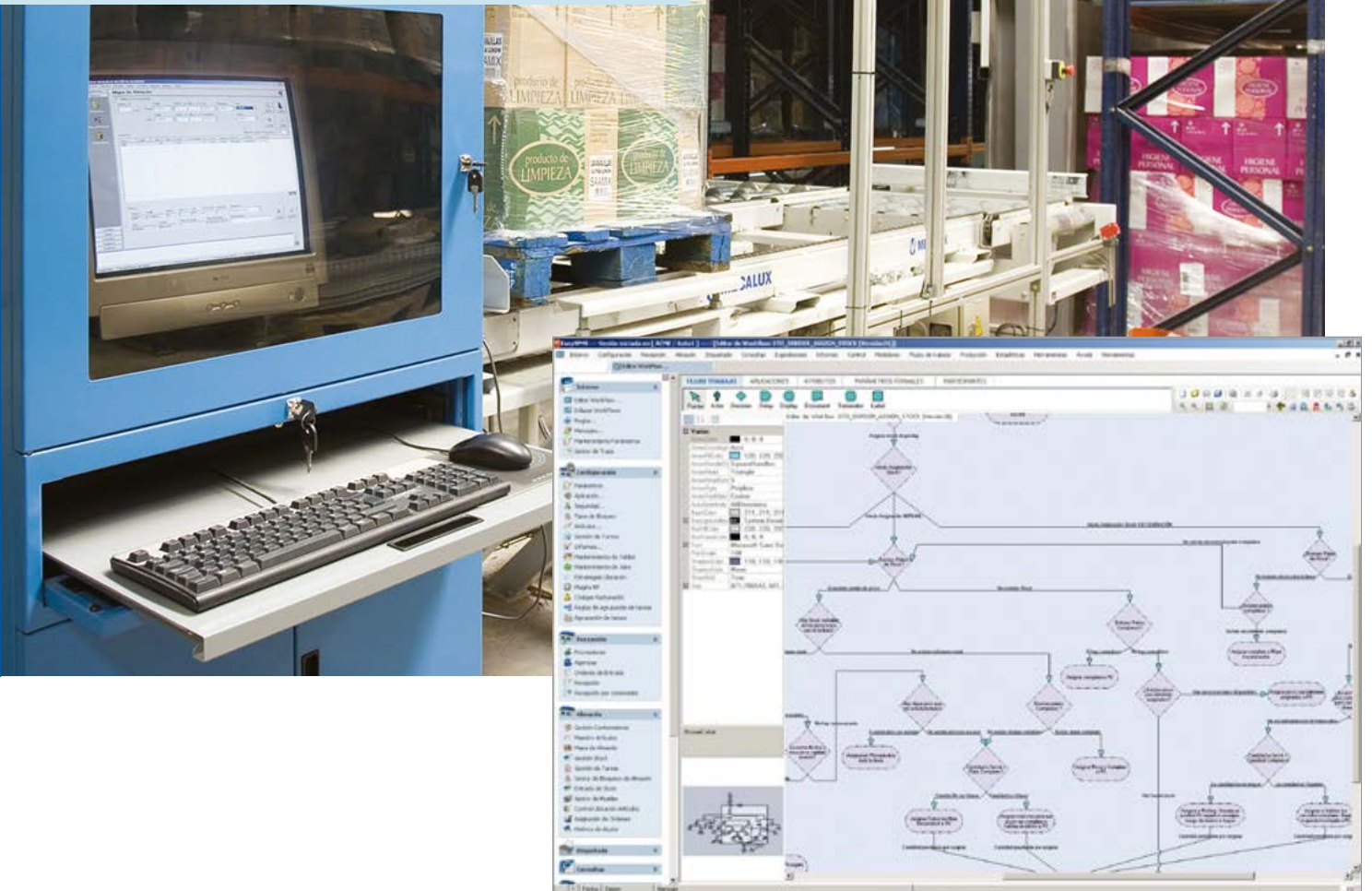

- **Warehouse service layer.** This level contains the distributed objects for the encapsulation of the programme's functionality, including all of the logic for each package. Redundant systems are incorporated to ensure adequate operation in fail-safe mode, whenever the installed hardware permits.
- **Data service layer.** This level deals with the acquisition of data from the installation through direct communication with the PC or the PLC cards.

Communications

Thanks to this architecture, the control system forms a comprehensive application, which can work both in a PC and PLC environment. In either case, the periphery devices and sensors distributed throughout the installation must be connected to a standard fieldbus (data transmission system), allowing all the components under control to be monitored.

The fieldbus used by Mecalux always corresponds to the global market standard, thus guaranteeing availability of compatible products and components from other international manufacturers.

The communication between the control software and the management software is established natively by TCP/IP communication.

Stations and routes are defined in the interface. A station is understood as those parts of the installation in which a route starts or ends. Stations are also positions in the installation that collect information on the flow of goods.

Toutes are all the possible paths that connect the different stations together.



Mecalux's warehouse management software, has been developed to allow for scalable installation, depending on the logistical complexity of the warehouse where it will be used. It is made up of six preset levels, ranging from zero possible software customisations, up to certain adaptations which can be made to the WMS.

EASY WMS WAREHOUSE MANAGEMENT SYSTEM

Functions of Easy WMS

The management software, the unit which integrates storage and distribution systems, consists of a set of computer applications, which interact with each other by means of information exchange mechanisms and communication protocols. Together with the ERP (Enterprise Resource Planning) system, the WMS manages and governs all the operations which take place in the warehouse.

The pyramid architecture of Easy WMS, organised in different management layers, is a way of defining the responsibilities and competencies of a software package that coexists with any ERP. Thus, the incompatibility of the Easy WMS system is minimal and the end result is optimal thanks to the software's versatility.

In the control and management hierarchy, Easy WMS is located immediately below a company's ERP from which it receives direct orders for the operations it must carry out (anticipated inputs, orders to dispatch, etc.). In turn, Easy WMS returns direct information on the result of the operations (actual quantities received, stock levels, incidents, etc.), avoiding intermediate layers of communication and reducing possible errors in data transmissions.

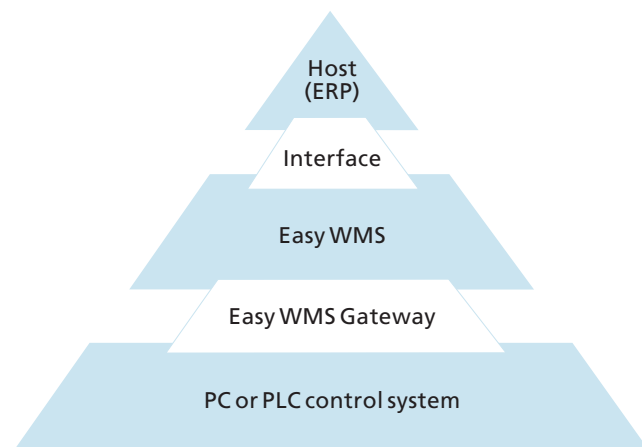

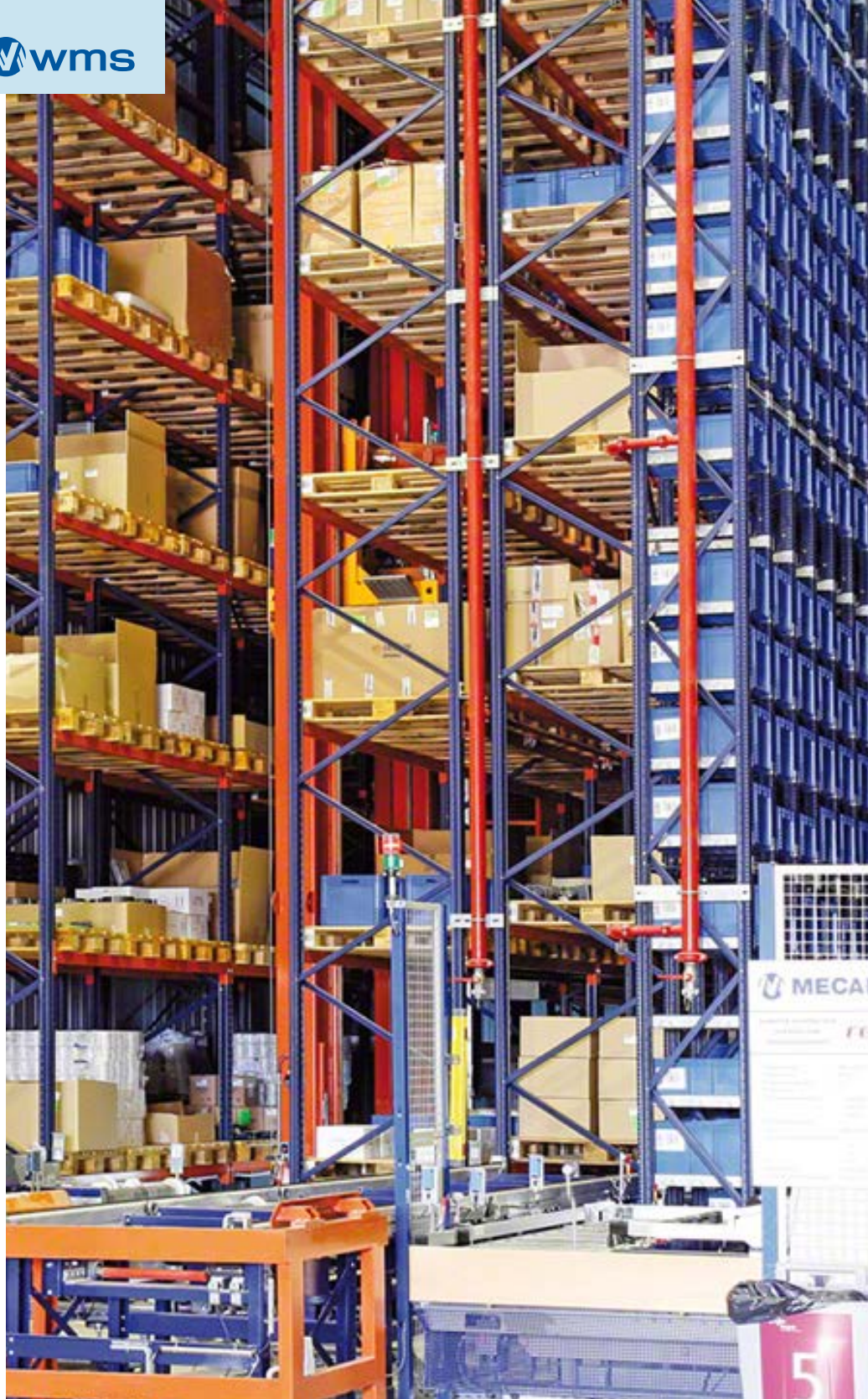

The control levels of the in-warehouse global functions and the distribution areas for goods are directly dependent on Easy WMS. As such, the ERP is relieved of tasks which are considered secondary, from the point of view of overall company management.

Easy WMS uses standard communication interfaces from the major ERPs on the market, developed to achieve maximum levels of security and stability.

The interfaces are programmed following two key principles:

- **The exchange of information between Easy WMS and the ERP must be independent** of their status. As a consequence, the protocol must allow communications to continue, when they are re-established and at the point they were interrupted.
- **The dialogue between the systems must be re-established automatically** when any failed structure is restarted, i.e. no manual actions should occur.

Mecalux continually certifies both its professionals and its WMS with the most widely used ERPs available on the market to guarantee the optimal running of the interfaces and communication protocols.

Mecalux has also developed a tool that makes deploying the WMS as easy as

possible. This application facilitates the graphic design, configuration and 3D simulation of warehouse operations, validating cycles, times and potential problems in a test environment.

Easy WMS functionalities

Easy WMS offers a wide variety of capabilities, allowing you to work efficiently with each process and in every area of the warehouse.

The functionalities are detailed as per the following central operation blocks:

- **Receipts** (entry of goods, unloading plans, returns, etc.).
- **Storage** (placement of goods on racks, restocking, recording movements, etc.).
- **Control** (stock management, rotation and relocation of items, report creation, etc.).
- **Dispatches** (goods leaving the warehouse, managing picking operations, shipping of goods, etc.).
- **Automated transport system** (station management in the system, gauge error control, etc.).
- **Tools** (report designer, label delivery, generic queries, consolidations, etc.).

→ EASY WMS: RECEIPT functionalities	
Entry orders	<ul style="list-style-type: none"> - The system allows the entry orders to be received by a communication interface. These entry orders are the equivalent to purchase orders or planned material entries (returns, third-party entries, etc.). They can contain data on the specific containers which are to be placed in the system (ASN) or data on quantities of material by SKU type.
Unloading plans	<ul style="list-style-type: none"> - The system allows unloading to be planned by time slots. - The system lets you print compliance reports with graphs to clearly see the delivery's degree of fulfillment by the hauler or supplier.
Receipts	<ul style="list-style-type: none"> - Receipt of goods without a prior entry order. - Creation of any number of receipts associated with an entry order. - Rectification of expected quantities due to excess or faulty goods. - Carry out receipt operations via a radiofrequency device, if needed.
Capture logistics data	<ul style="list-style-type: none"> - Confirm the delivery note's information to prevent errors. - Create new articles, if they do not exist in the system. - Create new presentations and palletise goods, if needed. - Control batches, serial numbers or expiry dates during the receipt of items with these required logistics attributes. - Control temperature and weight during the receipt of items with these required logistics attributes. - Control the owner of the goods.
Reception of documents	<ul style="list-style-type: none"> - Print receipt reports (both standard and custom). - Print discrepancy reports to show possible disparities between the material received and expected.
Barcode labelling	<ul style="list-style-type: none"> - Print labels for storage units (both standard and custom). - Print product labels (both standard and custom). - Management of practically all label printers available on the market.
Finalise receipts	<ul style="list-style-type: none"> - Close receipt orders and the associated receipts manually. - Cancel receipts to partially close receipt orders. - Close receipt orders and the associated receipts from within the management system (ERP).
Production entries	<ul style="list-style-type: none"> - Recognise production containers. - Cross-docking of containers to send directly to dispatch. - Container size control (height, spaces, runners). - Manage entries sent to reconditioning stations. - Communicate activation of goods in the ERP.
Returns	<ul style="list-style-type: none"> - Manual register of returns. - Register returns associated with an entry order. - Handle containers and their location according to the established rules.
Communication with host	<ul style="list-style-type: none"> - Automatic message sent to the ERP with the received material. - Automatic message sent to the ERP with the located material.



→ EASY WMS: STORAGE functionalities

<p>Location rules manager</p>	<ul style="list-style-type: none"> - Location following a set of rules. These can be defined to apply the following criteria: <ul style="list-style-type: none"> · Search by area and dimensions. · By product and/or presentation. · By supplier. · By owner. · By product rotation. · By condition of materials. · By weight. · By hazard level of product. · By container type. · By temperature. · By product type.
<p>Location manager</p>	<ul style="list-style-type: none"> - Management of the routes to the storage location to optimise operator movements on the way to the destination. - The operator can manually change the location suggested by the system.
<p>Cross-docking</p>	<ul style="list-style-type: none"> - Dispatch stock directly from the incoming dock, without going through storage.
<p>Tracking</p>	<ul style="list-style-type: none"> - Records all movements made with stock, and the storage units, providing total traceability within the warehouse, from when they enter the warehouse until dispatch.
<p>Automated defragmenting</p>	<ul style="list-style-type: none"> - The system is able to reorganise storage units in aisles using task programming during a time range, or during dips in production.
<p>Re-stocking</p>	<ul style="list-style-type: none"> - Manual re-stocking. - Automated restocking in picking locations, to ensure that stock is always available.
<p>Manual stock reserves</p>	<ul style="list-style-type: none"> - Association of certain stock to a customer. This stock will only be used to serve that specified customer. - Association of certain stock to a dispatch order. This stock will only be used to fulfil this order.

→ EASY WMS: STOCK CONTROL functionalities	
Display of warehouse and stock	- A graphic tool is available define and change stock statuses and locations, as well as reserve and block locations.
Dynamic rotation management	- Rotation calculations for each item within set dates, which can be selected by the user. - Creation of a report with suggested changes to SKU rotation. - Generation of stock re-location tasks based on the changes in product rotation and other location rules.
Recounts	- Based on: <ul style="list-style-type: none"> · Product or warehouse owner. · Product. · Storage unit. · Batch. · Serial number. · Aisle. · Storage area. · Warehouse coordinate range.
Lost & Found location management	- Virtual location available to manage problematic stock.

→ EASY WMS: DISPATCH functionalities	
Dispatch orders	- Dispatch orders are received via a communications interface, and are equivalent to sales or exit orders.
Dispatch planning	The system allows unloading to be planned in time slots. - Print compliance reports with graphs to show the degree of fulfillment. - Print custom reports.
Re-stocking	- Automated re-stocking in picking locations. - Manual re-stocking. - Manual re-stocking using RF devices.
Exit of goods	- Manage goods leaving the warehouse with the following characteristics: <ul style="list-style-type: none"> · Manage shipping routes (transportation). · Manage full pallets leaving the warehouse. · Manage full pallets leaving the warehouse, ordered by line.
Management of picking operations	- Picking using radiofrequency terminals or at a fixed station with a PC. - Management of different item presentations. - Stacker management. - Container-client management and management of container-client returns to the warehouse (pre-planned).
Pick-to-light / Put-to-light	- Management of PTL devices to carry out picking operations.
Loading lorries	- The system controls the loading of the goods contained in each order to the assigned lorry, to avoid mistakes. - Shipping route management.
Dispatch documentation	- Delivery notes per order or per group of orders. - Discrepancy reports between ordered and served goods. - Packing list per container. - Report of dispatch composition to unpack orders manually. - Relationship between containers, SKUs and orders loaded on a lorry. - Creation of custom reports.
Labelling goods	- Standard or custom labelling of containers. - Standard or custom labelling of products.
Communication with ERP	- Automated message about dispatched goods to the company's management system. - Automate message about goods loaded onto the delivery vehicle.



→ **EASY WMS: AUTOMATED TRANSPORT SYSTEM functionalities**

Stacker crane management	<ul style="list-style-type: none"> - Optimisation of stacker crane movements. - Management of stacker crane movements for cranes with more than one extractor and different depths, guaranteeing the maximum number of cycles.
Station management	<ul style="list-style-type: none"> - Possibility of managing blocks and basic operational changes in the system's stations.
Gauge error control	<ul style="list-style-type: none"> - Visual display of errors. - Possibility of resolving problems when reading labels, printing of reports and statistic of gauge errors.

→ **EASY WMS: TOOL functionalities**

Equipment management	<ul style="list-style-type: none"> - Manage the number and type of equipment that can work at any given time in the different areas or aisles.
Report designer	<ul style="list-style-type: none"> - System has a graphic report designer that can be adapted to suit any need.
Label designer	<ul style="list-style-type: none"> - System has a label designer that allows the customer to adjust formats to meet their requirements.
Safety	<ul style="list-style-type: none"> - Management of users and groups to ensure safe access.
General queries	<ul style="list-style-type: none"> - A wide variety of generic queries and reports that can be adapted to suit the needs of each customer.
Navigation	<ul style="list-style-type: none"> - Access different levels of information from a single screen.
Handling	<ul style="list-style-type: none"> - The system is controlled using a radiofrequency terminal, a fixed station with PC or paperwork.
Control panel	<ul style="list-style-type: none"> - Different warehouse parameters measured in real-time.



Some of the functions described in the tables for the different levels require highly-specific technological solutions. These include: pick-to-light/put-to-light functions included in the dispatches block, and the use of radiofrequency in warehouse operations.

PTL AND RADIOFREQUENCY DEVICES

Pick-to-light / Put-to-light

Architecture

The system is made up of devices known as tags, which are connected to a controller. This controller is connected by an Ethernet network to a PC, which manages these tags.

The system works approximately as shown in this diagram:

Pick-to-light operations

This system basically consists of a series of display devices, which are connected to an industrial PC in which the application is located. The extraction orders are sent from the WMS to the displays fitted in the racking, so the operator always knows the quantity of units to be extracted and where they are located.

Once the job is finished, the operator must validate the order by pressing a button on the side of the display panel, or correct the stock, if there is not enough material.

The system eliminates paper-based lists and can be fitted on any type of racking.

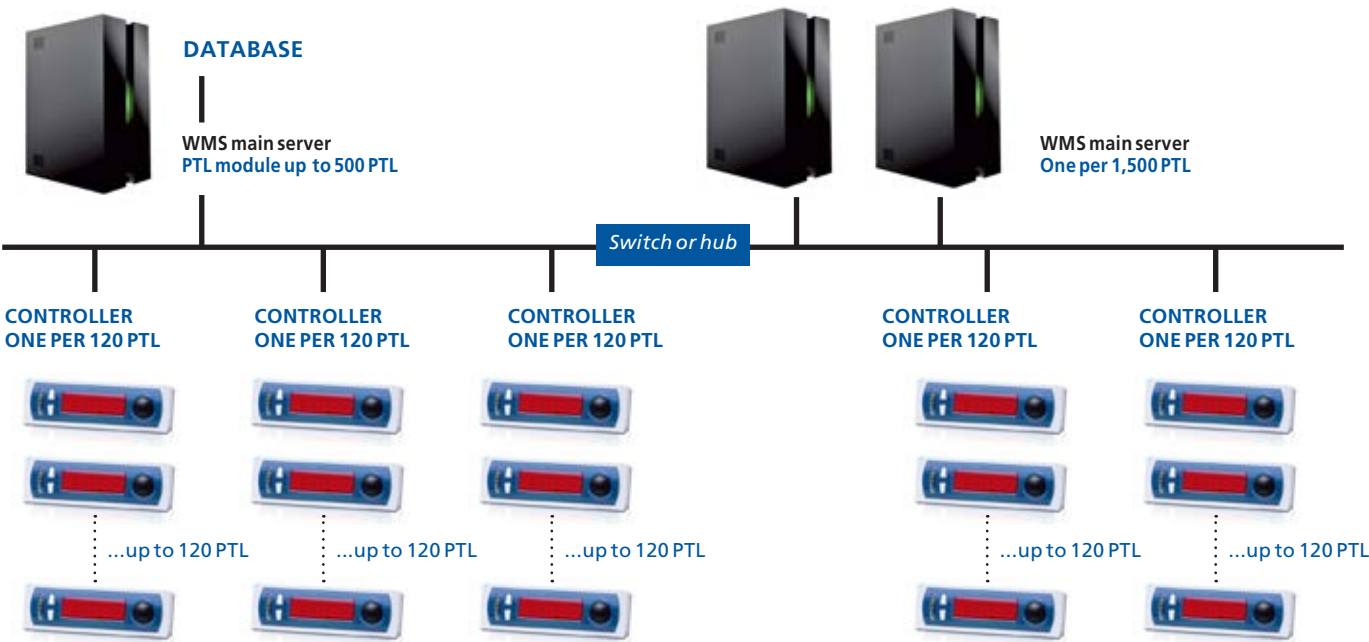



Put-to-light operations

This operation is the opposite of the pick-to-light system. In other words, the items are taken in batches from the warehouse, and are transported to the position of the operator. As soon as the goods are collected, the operator must scan one of the articles or identify the cart in which the material is delivered.

All the locations where the scanned articles are to be deposited automatically appear on the illuminated display, indicating the quantity to be deposited in each position. The operator places the article where instructed, and presses the display to confirm the action. As soon as this is done, the displayed instruction disappears.

Radiofrequency (RF) devices

Radiofrequency devices are connected directly to the Easy WMS data server, as if it were a standard ethernet connection. This allows all the terminals to be integrated in the management network, enabling the operation to be performed by radiofrequency from different terminal models at the same time.

The architecture of the radiofrequency system integrated in the Mecalux WMS is shown in the following diagram:

Module for integrating external systems

On certain occasions, the logistics solution developed for the customer's needs requires the integration of specific closed systems that have not been manufactured or supplied by Mecalux.

Easy WMS incorporates a special module, which enables interaction with these products to not limit this type of installation.

These include:

- Loading/unloading of lorries.
- Automated guided vehicles.
- Sorters.
- Other.





Plant in Tijuana (Mexico)



Plant in Pontiac (USA)



Plant in Chicago (USA)



Plant in Gijón (Spain)



Plant in Gliwice (Poland)



Plant in Matamoros (Mexico)



Plant in Sumter (USA)



Plant in Palencia (Spain)



Plant in Barcelona (Spain)



Plant in Buenos Aires (Argentina)



Plant in São Paulo (Brazil)

- Sales network
- Production centres



Visit mecalux.pl for more information.





For more information, visit our website: mecalux.pl
or email: info@mecalux.pl

ЗАВОД

ГЛИВИЦЕ

tel.: (+48) 32-331 69 66
ul. Wyszółkowskiego 125
44-109 Gliwice

КОММЕРЧЕСКИЕ ОТДЕЛЫ

ВАРШАВА

tel.: (+48) 22-654 56 81
e-mail: warszawa@mecalux.com

КРАКОВ

tel.: (+48) 12-686 38 70 (71)
e-mail: krakow@mecalux.com

ПОЗНАНЬ

tel.: (+48) 61-665 97 87
e-mail: poznan@mecalux.com

ВРОЦЛАВ

tel.: (+48) 71-793 88 29
e-mail: wroclaw@mecalux.com

ГДЫНЯ

tel.: (+48) 58-761 80 80
e-mail: gdansk@mecalux.com

Месалух присуствует в более чем 70 странах мира

Офисы в: АРГЕНТИНА - БЕЛЬГИЯ - БРАЗИЛИЯ - ЧЕХИЯ - ЧИЛИ - ФРАНЦИЯ - ИСПАНИЯ - ГОЛЛАНДИЯ - КАНАДА - КОЛУМБИЯ
МЕКСИКА - ГЕРМАНИЯ - ПЕРУ - ПОЛЬША - ПОРТУГАЛИЯ - СЛОВАКИЯ - ТУРЦИЯ - США - ВЕЛИКОБРИТАНИЯ - ИТАЛИЯ - УРУГВАЙ

